

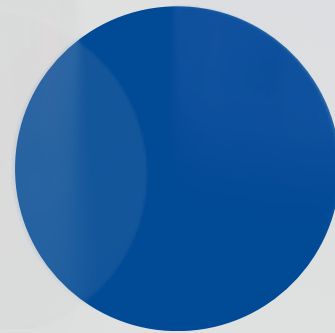

Leadshine

Stock Code: 002979



Stepper Products

Product Catalogue

www.leadshine.com

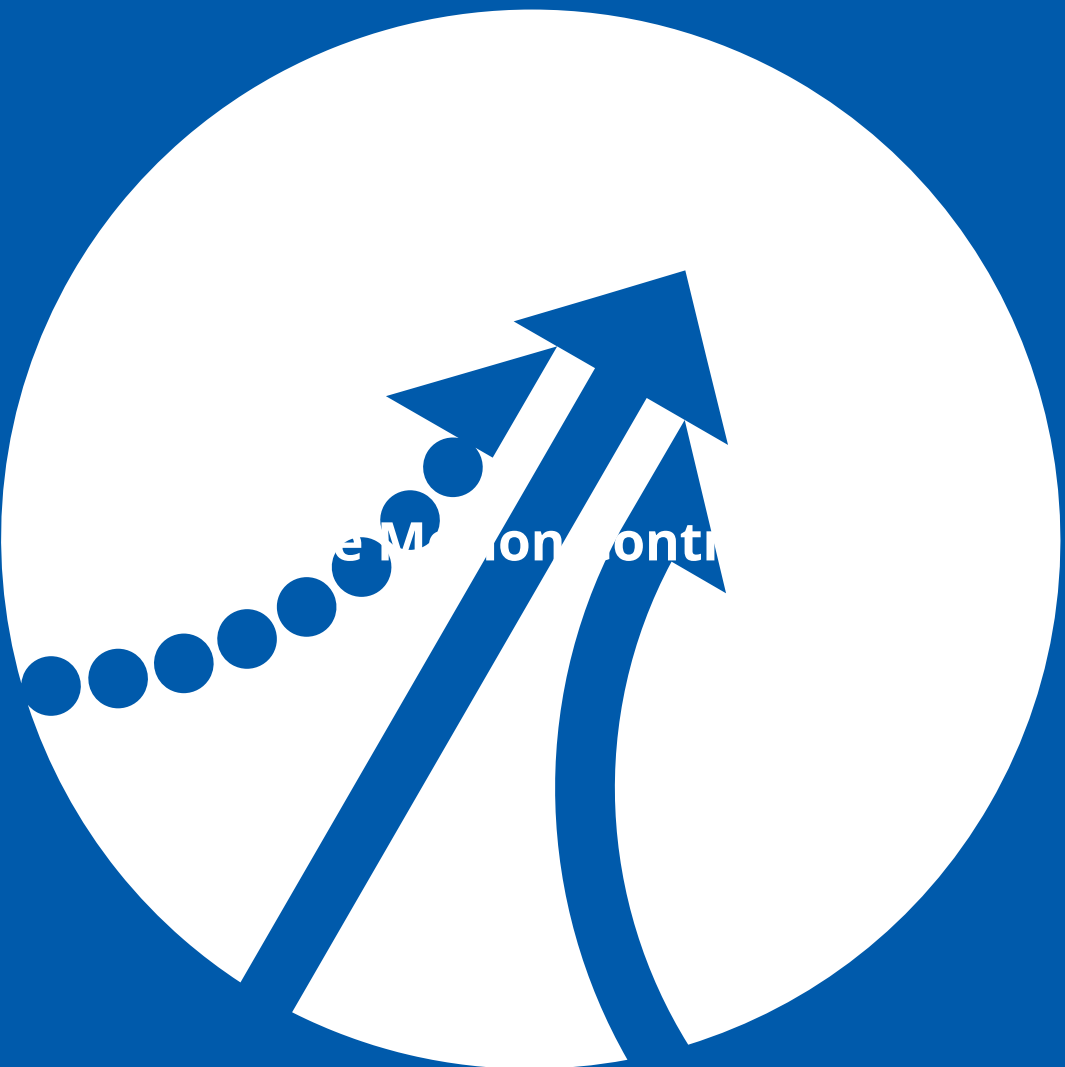

• **Page Index** 01-19

- Company Profile Product
- System Product Quick
- Selection Typical Industry
- Applications Product
- Overview

• **Digital Stepper Motors and Drives** 20-63

- Part Numbers
- Fieldbus Stepper Drives
 - 2EM3EIP / 2EM3E Dual-axis Series 2
 - EM3E Series 1
 - EM2RS Series 2
- Pulse Control Stepper Drives
 - EM-S/DM-E Series 2
 - EM1 Series 9
- CM Series Stepper Motors 1
- 5-phase Stepper Drives 3
- 7
- 4
- 1
- 5

• **Closed Loop Stepper Motors and Drives** 64-86

- Part Numbers
- Fieldbus Closed Loop Stepper Drives
 - 2CS3EIP / 2CS3E Dual-axis Series 6
 - CS3E Series 5
 - CS2RS Series 6
- Pulse Control Closed Loop Stepper Drives
 - CS1/CS Series 9
- CS-M Series Closed Loop Stepper Motors 7
- 5
- 7
- 9

• **Integrated Stepper Motors** 87-90

- Integrated Stepper Motors

• **Other Products** 91-92

- LSP Series Power Supplies
- PLF Series Gearboxes



Headquarters in Shenzhen



Shanghai Intelligent Industry Park



Production base in Shenzhen

- **Founded in 1997**
- **Public Listed Company in China (002979.SZ)**
- **Dedication in Motion Control**
Stepper/Servo systems, Motion Controllers, PLC
Control systems, I/O Modules, Encoders
- **A leading supplier of motion control products and solutions in the world**
- **Customer Oriented, Technology Oriented, Forever Improving, Sharing of Success**

25+ Experience 400+ R&D Engineers 5 Subsidiaries 60+ Countries Clients 10000+ Global Partners 30million+ Installed Axes

Leadshine Motion Control Total Product System



Leadshine Stepper Systems Quick Selection

Stepper Motors

Below matched drive is default Pulse & Direction type, other control types of drive also can be matched;

3-phase stepper motors still keep selling 3S series, others recommend CM series;

Contact Leadshine for other customized model such as inch shaft diameters, modified cable, etc.

| Phase/ Series | Frame Size | Length (mm) | Model | Rate Current (A) | Holding Torque (N.m) | Matched Drives | Remark |
|---------------|------------|-------------|-----------|------------------|-----------------------|-----------------------|---------------------------|
| 2- Phase/CM | NEMA 8 | 3 | 20CM003 | 0.6 | 0.03 | EM415S | |
| | | 3 | 20CM005 | 0.6 | 0.05 | EM415S | |
| | NEMA 11 | 4 | 20CM006 | 1.2 | 0.06 | EM415S | |
| | | 5 | 20CM0010 | 1.2 | 0.1 | EM415S | |
| | NEMA 14 | 3 | 20CM0013 | 1.2 | 0.13 | EM415S | |
| | | 2 | 35CM015 | 2.0 | 0.15 | EM422S | |
| | NEMA 17 | 1 | 42CM02-1A | 1.0 | 0.2 | EM415S | |
| | | | 42CM02 | 1.5 | 0.2 | EM422S | |
| | | 1 | 42CM04-1A | 1.0 | 0.4 | EM415S | |
| | | | 42CM04 | 1.5 | 0.4 | EM422S | |
| | | 1 | 42CM06-1A | 1.5 | 0.6 | EM422S | |
| | | | 42CM06 | 2.5 | 0.6 | EM422S/EM542S | Performance in high-speed |
| | | 47 | 42CM06-SZ | 2.5 | 0.8 | EM422S/EM542S | Motor with dual shaft |
| | | | 42CM08-1A | 1.5 | 0.8 | EM422S | |
| | | 60 | 42CM08 | 2.5 | 0.8 | EM422S/EM542S | Performance in high-speed |
| | | | 42CM08-SZ | 2.5 | 0.8 | EM422S/EM542S | Motor with dual shaft |
| | NEMA 23 | 41 | 57CM06 | 3.0 | 0.6 | EM542S | |
| | | | 57CM13-3A | 3.0 | 1.3 | EM542S | |
| | | 56 | 57CM13 | 4.0 | 1.3 | EM556S | Performance in high-speed |
| | | | 57CM13-SZ | 4.0 | 1.3 | EM556S | Motor with dual shaft |
| | | 9 | 57CM13-BZ | 4.0 | 1.3 | EM556S | Motor with brake |
| | | | 57CM13-FS | 4.0 | 1.3 | EM556S | IP65 waterproof |
| | | 6 | 57CM23-3A | 3.0 | 2.3 | EM542S | |
| | | | 57CM23-4A | 4.0 | 2.3 | EM556S | |
| | | 5 | 57CM23 | 5.0 | 2.3 | EM556S/EM870S | Performance in high-speed |
| | | | 57CM23-SZ | 5.0 | 2.3 | EM556S/EM870S | Motor with dual shaft |
| | NEMA 23 | 116 | 57CM23-BZ | 5.0 | 2.3 | EM556S/EM870S | Motor with brake |
| | | | 57CM23-FS | 5.0 | 2.3 | EM556S/EM870S | Motor with waterproof |
| | | 84 | 57CM26-4A | 4.0 | 2.6 | EM556S | |
| | | | 57CM26 | 5.0 | 2.6 | EM556S/EM870S | Performance in high-speed |
| | | 57CM26-SZ | 5.0 | 2.6 | EM556S/EM870S | Motor with dual shaft | |
| | | | 67 | D57CM21-4A | 4.0 | 2.1 | EM556S |
| | | D57CM21 | | 5.0 | 2.1 | EM556S/EM870S | Performance in high-speed |
| | | D57CM21-SZ | 5.0 | 2.1 | EM556S/EM870S | Motor with dual shaft | |
| | | | 88 | D57CM31-4A | 4.0 | 3.1 | EM556S |
| | | D57CM31 | | 5.0 | 3.1 | EM556S/EM870S | Performance in high-speed |
| | D57CM31-SZ | 5.0 | 3.1 | EM556S/EM870S | Motor with dual shaft | | |

| Phase/ Series | Frame Size | Length (mm) | Model | Rate Current (A) | Holding Torque (N.m) | Matched Drives | Remark | |
|---------------|------------|-------------|-------------|------------------|----------------------|----------------|-----------------------|--------|
| 2-Phase/CM | NEMA 24 | 67 | 60CM22X | 5.0 | 2.2 | EM556S/EM870S | Motor with dual shaft | |
| | | | 60CM22X-SZ | 5.0 | 2.2 | EM556S/EM870S | Motor with brake | |
| | | 110 | 60CM35X-FS | 5.0 | 2.2 | EM556S/EM870S | | |
| | | | 60CM30X | 5.0 | 3.0 | EM556S/EM870S | | |
| | | 85 | 60CM30X-SZ | 5.0 | 3.0 | EM556S/EM870S | Motor with dual shaft | |
| | | | 60CM30X-BZ | 5.0 | 3.0 | EM556S/EM870S | Motor with brake | |
| | NEMA 34 | 65 | 86CM35 | 4.0 | 3.5 | EM882S | | |
| | | | 86CM45B | 6.0 | 4.5 | EM882S | | |
| | | 80 | 86CM45B-I14 | 6.0 | 4.5 | EM882S | | |
| | | | 86CM45-SZ | 6.0 | 4.5 | EM882S | Motor with dual shaft | |
| | | 114 | 86CM45-BZ | 6.0 | 4.5 | EM882S | Motor with brake | |
| | | | 86CM45-FS | 6.0 | 4.5 | EM882S | Motor with waterproof | |
| | | 90 | 86CM80 | 6.0 | 8.0 | EM882S | | |
| | | | 86CM85B | 6.0 | 8.5 | EM882S | | |
| | | 118 | 86CM85B-I14 | 6.0 | 8.5 | EM882S | | |
| | | | 86CM85-SZ | 6.0 | 8.5 | EM882S | Motor with dual shaft | |
| | | 152 | 86CM85-BZ | 6.0 | 8.5 | EM882S | Motor with brake | |
| | | | 86CM85-FS | 6.0 | 8.5 | EM882S/DM1182 | Motor with waterproof | |
| | | NEMA 23 | 129 | 86CM120 | 3.0 | 0.6 | DM2282 | |
| | | | | 115 | 110CM12 | 3.0 | 1.3 | DM2282 |
| | 150 | | 110CM20 | 4.0 | 1.3 | DM2282 | | |
| | | | 110CM28 | 4.0 | 1.3 | DM2282 | | |
| | 201 | | 130HS45 | 3.5 | 0.9 | 3DM580S | | |
| | | | 573S09 | 5.8 | 1.5 | 3DM580S | | |
| | NEMA 51 | 76 | 573S15 | 5.8 | 1.5 | 3DM580S | | |
| | | | 573S20-LS | 5.0 | 2.2 | 3DM883 | | |
| | | 71 | 863S22 | 5.0 | 4.2 | 3DM883 | | |
| | | | 863S42 | 2.3 | 6.8 | 3DM2283 | | |
| | | 103 | 863S68H | | | | | |
| | | | 135 | | | | | |

| Phase/ Series | Frame Size | Length (mm) | Model | Rate Current (A) | Holding Torque (N.m) | Matched Drives | Remark | |
|---------------|------------|-------------|------------------|------------------|----------------------|----------------|-------------------|--------------|
| 2-Phase/CM | NEMA 11 | 51 | 28CM013-ZK | 1.2 | 0.13 | EM415S | Hollow shaft | |
| | | | 42CM04-ZK | 2.5 | 0.4 | EM422S | Hollow shaft | |
| | NEMA 17 | 79 | 42CM06-BZ | 2.0 | 0.6 | EM422S | Brake | |
| | | | 42CM06-RD05 | 2.5 | 0.6 | EM422S/EM542S | Gearbox | |
| | | 88 | 42CM06-RD10 | 2.5 | - | EM422S/EM542S | Gearbox | |
| | | | 42CM06-RD20 | 2.5 | - | EM422S/EM542S | Gearbox | |
| | | 95 | 42CM08-BZ | 2.0 | 0.8 | EM422S/EM542S | Gearbox | |
| | | | 42CM08-RD05 | 2.5 | - | EM422S/EM542S | Brake | |
| | | 101 | 42CM08-RD10 | 2.5 | - | EM422S/EM542S | Gearbox | |
| | | | 42CM08-RD20 | 2.5 | - | EM422S/EM542S | Gearbox | |
| | | 60 | 42CM08-SZ-ZK | 3.0 | 0.8 | EM422S/EM542S | Gearbox | |
| | | | 57CM12C-3A-CZ | 4.0 | 1.2 | EM542S | Hollow shaft | |
| | NEMA 23 | 55 | 57CM12C-ZK | 4.0 | 1.2 | EM542S/EM556S | Plug-in terminals | |
| | | | 57CM12C-RD05 | 4.0 | - | EM542S/EM556S | Hollow shaft | |
| | | 110 | 57CM12C-RD10 | 4.0 | - | EM542S/EM556S | Gearbox | |
| | | | 57CM12C-RD10 | 4.0 | - | EM556S | Gearbox | |
| | | 76 | 57CM22C-4A-I6-CZ | 5.0 | 2.2 | EM556S | Plug-in terminals | |
| | | | 57CM22C-RD05 | 5.0 | - | EM556S | Gearbox | |
| | | 131 | 57CM22C-RD10 | 6.0 | - | EM556S | Gearbox | |
| | | | 57CM22C-RD10 | 6.0 | - | EM556S | Gearbox | |
| | | NEMA 34 | 98 | 86CM80-ZK | | 8.0 | | Hollow shaft |
| | | | | | | | | |

Close Loop Stepper Drives

| Series | Model | Matched Motor Series | Command Source | | | | Electrical Parameters | | | Motion Function Features | | | | | I/O | | Others | | | | | | |
|-------------------------|----------------|----------------------|----------------|----------|--------------|---------|-----------------------|-----------------------|-----------------------|--------------------------|--------------|--------------|-----------|----------------|---------------------|---------------|----------------|----------------------|---------------|-----------------|-------------------|-------------------|---------------|
| | | | EtherNet/IP | EtherCAT | RS485 Modbus | Pul&Dir | CW&CCW | Power Voltage | Output Current | Logical Voltage | Alarm Output | Brake Output | Self Test | Anti-resonance | Auto-tuning Disable | Digital Input | Digital Output | Mechanical Size (mm) | Tuning Cable | Tuning Software | | | |
| 2EM3EIP | 2EM3EIP-522 | CM Series | √ | | | | | 20-50VDC | 0.5-2.2A | 12-24V | | √ | √ | √ | √ | √ | 2*4 | 2*2 | 155*116.5*28 | CABLE-USB1M5 | Motion Studio | | |
| | 2EM3EIP-556 | | √ | | | | | 20-50VDC | 1.0-5.6A | 12-24V | | √ | √ | √ | √ | √ | 2*4 | 2*2 | 155*116.5*28 | | | | |
| | 2EM3EIP-870 | | √ | | | | | 20-80VDC | 1.0-7.0A | 12-24V | | √ | √ | √ | √ | √ | 2*4 | 2*2 | 155*116.5*28 | | | | |
| 2EM3E | 2EM3E-522 | | | √ | | | | | 20-50VDC | 0.5-2.2A | 12-24V | | √ | √ | √ | √ | √ | 2*4 | 2*2 | 155*116.5*28 | | CABLE-TYPEC2M0 | Motion Studio |
| | 2EM3E-556 | | | √ | | | | | 20-50VDC | 1.0-5.6A | 12-24V | | √ | √ | √ | √ | √ | 2*4 | 2*2 | 155*116.5*28 | | | |
| | 2EM3E-870 | | | √ | | | | | 20-80VDC | 1.0-7.0A | 12-24V | | √ | √ | √ | √ | √ | 2*4 | 2*2 | 155*116.5*28 | | | |
| EM3E | EM3E-522B | | | | √ | | | | 20-50VDC | 0.3-2.2A | 12-24V | | √ | √ | √ | √ | √ | 6 | 2 | 118*90*28 | CABLE-USB1M5 | Standard ProTuner | |
| | EM3E-556B | | | | √ | | | | 20-50VDC | 1.0-5.6A | 12-24V | | √ | √ | √ | √ | √ | 6 | 2 | 118*90*28 | | | |
| | EM3E-570B | | | | √ | | | | 20-50VDC | 1.0-7.0A | 12-24V | | √ | √ | √ | √ | √ | 6 | 2 | 118*90*28 | | | |
| EM2RS | EM3E-A882 | | | | √ | | | | 18-80VAC 30-110VDC | 0.3-2.2A | 12-24V | | √ | √ | √ | √ | √ | 7 | 7 | 151*113*40 | CABLE-USB1M5 | Motion Studio | |
| | EM2RS-522 | | | | √ | | | | 20-50VDC | 0.5-5.6A | 12-24V | | √ | √ | √ | √ | √ | 7 | 3 | 118*79.5*25.5 | | | |
| | EM2RS-556 | | | | √ | | | | 20-50VDC | 0.5-7.0A | 12-24V | | √ | √ | √ | √ | √ | 7 | 3 | 118*79.5*25.5 | | | |
| | EM2RS-870 | | | | √ | | | | 20-80VDC | 0.5-8.2A | 12-24V | | √ | √ | √ | √ | √ | 7 | 3 | 118*79.5*25.5 | | | |
| | EM2RS-A882 | | | | √ | | | | 18-80VAC 30-110VDC | 0.3-1.5A | 5V | | √ | √ | √ | √ | √ | 7 | 3 | 151*97*53 | | | |
| EM-S | EM415S (V2.0) | | | | | √ | √ | | 12-40VDC | 0.3-3.2A | 5V | | √ | √ | √ | √ | √ | 3 | 1 | 86*55*20 | CABLE-PC-1 | Standard ProTuner | |
| | EM422S (V2.0) | | | | | √ | √ | | 12-40VDC | 0.5-4.2A | 5/24V | | √ | √ | √ | √ | √ | 3 | 1 | 86*55*20 | | | |
| | EM532MINI | | | | | √ | √ | | 18-50VDC | 0.5-5.6A | 5/24V | | √ | √ | √ | √ | √ | 3 | 1 | 62*50*26 | | | |
| | EM542S (V3.0) | | | | | √ | √ | | 20-50VDC | 0.5-7.0A | 5/24V | | √ | √ | √ | √ | √ | 3 | 1 | 118*75.5*25.5 | | | |
| | EM556S (V3.0) | | | | √ | √ | | 20-50VDC | 0.5-8.2A | 5V | | √ | √ | √ | √ | √ | 3 | 2 | 118*75.5*34 | | | | |
| | EM870S (V3.0) | | | | √ | √ | | 20-80VDC | 0.3-2.2A | 5~24V | | √ | √ | √ | √ | √ | 3 | 2 | 118*75.5*34 | | | | |
| | EM882S | | | | √ | √ | | 20-80VDC | 0.3-3.2A | 5~24V | | √ | √ | √ | √ | √ | 3 | 2 | 118*75.5*34 | | | | |
| EM1 | EM1-422 | | | | √ | √ | | 20-36VDC | 0.5-4.2A | 5~24V | | √ | √ | √ | √ | √ | 3 | 1 | 151*97*48 | CABLE-PC-1 | Motion Studio | | |
| | EM1-432 | | | | √ | √ | | 20-36VDC | 0.5-5.6A | 5~24V | | √ | √ | √ | √ | √ | 3 | 2 | 86*55.5*20.5 | | | | |
| | EM1-542 | | | | √ | √ | | 24-50VDC | | 5~24V | | √ | √ | √ | √ | √ | 3 | 2 | 86*55.5*20.5 | | | | |
| | EM1-556 | | | | √ | √ | | 24-50VDC | | 5~24V | | √ | √ | √ | √ | √ | 3 | 2 | 118*75.5*25.5 | | | | |
| | EM1-870 | | | | √ | √ | | 24-80VDC | 0.5-7.0A | 5V | | √ | √ | √ | √ | √ | 3 | 2 | 118*75.5*34 | | | | |
| | EM1-882AC | | | | √ | √ | | 20-70VAC | | 5V | | √ | √ | √ | √ | √ | 3 | 2 | 118*75.5*34 | | | | |
| DM-E | DM322E | | | | √ | √ | | 30-100VDC | 0.5-8.2A | 5/24V | | √ | √ | √ | √ | √ | 3 | 2 | 151*97*52 | CABLE-PC-1 | Standard ProTuner | | |
| | DM332E | | | | √ | √ | | 12-30VDC | 0.3-2.2A | 5V | | √ | √ | √ | √ | √ | 3 | 0 | 86*55*20 | | | | |
| | DM542E (V3.0) | | | | √ | √ | | 12-30VDC | 1.0-3.2A | 5/24V | | √ | √ | √ | √ | √ | 3 | 0 | 86*55*20 | | | | |
| | DM556E (V3.0) | | | | √ | √ | | 20-50VDC | 1.0-4.2A | | | √ | √ | √ | √ | √ | 3 | 0 | 118*75.5*25.5 | | | | |
| | DM860E | | | | √ | √ | | 20-50VDC | 1.7-5.6A | | | √ | √ | √ | √ | √ | 3 | 0 | 118*75.5*34 | | | | |
| | DMA860E (V3.0) | | | | √ | √ | | 20-80VDC | 2.4-7.2A | 2.4-7.2A | | √ | √ | √ | √ | √ | 3 | 0 | 151*97*42.5 | | | | |
| DM (AC input / 3 phase) | | | | | √ | √ | | 18-80VAC 30-110VDC | | | | √ | √ | √ | √ | √ | 3 | 2 | 151*97*57 | CABLE-PC-1 | Standard ProTuner | | |
| | DMA860H | | | | √ | √ | | 18-80VAC 30-110VDC | 2.4-7.2A | 5V | | √ | √ | √ | √ | √ | 3 | 0 | 151*97*53 | | | | |
| | DMA882S | | | | √ | √ | | 18-80VAC | 30-110VDC | 5V | | √ | √ | √ | √ | √ | 3 | 1 | 151*97*53 | | | | |
| | DM1182 | HS&CM Series | | | | √ | √ | | 70-130VAC | 0.5-8.2A | 5V | | √ | √ | √ | √ | 3 | 1 | 200*145*83 | | | | |
| | DM2282 | | | | √ | √ | | 180-240VAC | 0.5-8.2A | 5V | | √ | √ | √ | √ | √ | 3 | 1 | 200*145*83 | | | | |
| | 3DM580S | 3S Series | | | | √ | √ | | 20-50VDC | 0.5-8.2A | 5/24V | | √ | √ | √ | √ | √ | 3 | 1 | | | 118*75.5*34 | |
| | 3DM883 | | | | | √ | √ | | 20-80VDC | 2.2-8.3A | 5/24V | | √ | √ | √ | √ | √ | 3 | 2 | | | 151*97*57 | |
| 3DM2283 | | | | | √ | √ | | 180-240VAC | 2.2-11.7A | | | √ | √ | √ | √ | √ | 3 | 1 | 200*145*83 | | | | |

Closed Loop Stepper Motors

Below matched drives are Pulse Control type, EtherCAT and Modbus RS485 types are also available;
 3-phase high voltage closed loop stepper motors are ES2-MH series, others are CS-M series;
 Maximum speed up to 3000 rpm, but depends on power voltage, current and load;

| Phase/Series | Frame Size | Length (mm) | Model | Holding Torque (N.m) | Matching Drives | Remark |
|--------------|------------|-------------|--------------|----------------------|-----------------------|------------------------------|
| 2-phase/CS-M | NEMA 17 | 56 | CS-M21702 | 0.2 | CS-D507E/CS1-D507S | |
| | | 63 | CS-M21704 | 0.4 | CS-D507E/CS1-D507S | |
| | | 70 | CS-M21706 | 0.6 | CS-D507E/CS1-D507S | |
| | | 83 | CS-M21708 | 0.8 | CS-D507E/CS1-D507S | |
| | NEMA 23 | 60 | CS-M22306 | 0.6 | CS-D507E/CS1-D507S | |
| | | 75 | CS-M22313 | 1.3 | CS-D507E/CS1-D507S | Replace ES-M22310 |
| | | 109 | CS-M22313B | 1.3 | CS-D507E/CS1-D507S | Motor with brake |
| | | 94 | CS-M22313WP | 1.3 | CS-D507E/CS1-D507S | Motor with waterproof |
| | | 95 | CS-M22323 | 2.3 | CS-D507E/CS1-D507S | Replace ES-M22320 |
| | | 131 | CS-M22323B | 2.3 | CS-D507E/CS1-D507S | Motor with brake |
| | | 115 | CS-M22323WP | 2.3 | CS-D507E/CS1-D507S | Motor with waterproof |
| | | 103 | CS-M22326 | 2.6 | CS-D507E/CS1-D507S | |
| | | 86 | CS-M22321-L | 2.1 | CS-D507E/CS1-D507S | NEMA23 motor with large body |
| | | 105 | CS-M22331-L | 3.1 | CS-D507E/CS1-D507S | NEMA23 motor with large body |
| | | 89 | CS-M22422 | 2.2 | CS-D507E/CS1-D507S | |
| | | 129 | CS-M22422B | 2.2 | CS-D507E/CS1-D507S | |
| | | 113 | CS-M22422WP | 2.2 | CS-D507E/CS1-D507S | Motor with brake |
| | | 107 | CS-M22430 | 3.0 | CS-D507E/CS1-D507S | Motor with waterproof |
| | | 143 | CS-M22430B | 3.0 | CS-D507E/CS1-D507S | |
| | | NEMA 24 | 130 | CS-M22430WP | 3.0 | CS-D507E/CS1-D507S |
| | 95 | | CS-M23435 | 3.5 | CS-D1008E | Motor with waterproof |
| | 109 | | CS-M23445 | 4.5 | CS-D1008E | |
| | 144 | | CS-M23445B | 4.5 | CS-D1008E | |
| | NEMA 34 | 115 | CS-M23445WP | 4.5 | CS-D1008E | Motor with brake |
| | | 127 | CS-M23480 | 8.0 | CS-D1008E | Motor with waterproof |
| | | 152 | CS-M23480B | 8.0 | CS-D1008E | |
| | | 133 | CS-M23480WP | 8.0 | CS-D1008E | Motor with brake |
| | | 147 | CS-M23485 | 8.5 | CS-D1008E | Motor with waterproof |
| | | 182 | CS-M23485B | 8.5 | CS-D1008E | |
| | | 153 | CS-M23485WP | 8.5 | CS-D1008E | Motor with brake |
| | | 158 | CS-M234120 | 12 | CS-D1008E | Motor with waterproof |
| | | 193 | CS-M234120B | 12 | CS-D1008E | |
| | | 164 | CS-M234120WP | 12 | CS-D1008E | Motor with brake |
| | | | | | Motor with waterproof | |

| Phase/Series | Frame Size | Length (mm) | Model | Holding Torque (N.m) | Matching Drives | Remark |
|----------------|------------|-------------|----------------|----------------------|-----------------|-----------------------|
| 3-phase/ES2-MH | NEMA 17 | 15 | ES2-MH33480 | 8.0 | ES-DH2306 | |
| | | 7 | ES2-MH33480B | 8.0 | ES-DH2306 | Motor with brake |
| | | 19 | ES2-MH33480WP | 8.0 | ES-DH2306 | Motor with waterproof |
| | | 0 | ES2-MH334100 | 10 | ES-DH2306 | |
| | NEMA 23 | 16 | ES2-MH334100B | 10 | ES-DH2306 | Motor with brake |
| | | 2 | ES2-MH334100WP | 10 | ES-DH2306 | Motor with waterproof |
| | | 18 | ES2-MH342120 | 12 | ES-DH2306 | |
| | | 4 | ES2-MH342120B | 12 | ES-DH2306 | Motor with brake |
| | | 21 | ES2-MH342120WP | 12 | ES-DH2306 | Motor with waterproof |
| | | 8 | ES2-MH342200 | 20 | ES-DH2306 | |
| | | 19 | | | | |
| | | 1 | | | | |
| | | 16 | | | | |

| Phase/Series | Frame Size | Length (mm) | Model | Holding Torque (N.m) | Matching Drives | Remark |
|--------------|------------|-------------------|----------------|----------------------|-------------------------|-------------------------|
| 2-phase/CS-M | NEMA 8 | 20 | | | | |
| | | 51 ₇ | CS-M208003 | 0.03 | CS-D507E | - |
| | NEMA 11 | 16 | | | | |
| | | 62 ₁₆ | CS-M211013 | 0.13 | CS-D507E | - |
| | NEMA 17 | 7 | | | | |
| | | 93 ₇ | CS-M21704B | 0.4 | CS-D507E | Brake |
| | | 101 ₂₄ | CS-M21706B | 0.6 | CS-D507E | Brake |
| | NEMA 17 | 4 | | | | |
| | | 113 ₄ | CS-M21708B | 0.8 | CS-D507E | Brake |
| | NEMA 23 | 96 | CS-M22323-S | 2.3 | CS-D507E | 1/4-inch shaft diameter |
| | | 104 | CS-M22326-S | 2.6 | CS-D507E | 1/4-inch shaft diameter |
| | | 105 | CS-M22331-L-S | 3.1 | CS-D507E | 3/8-inch shaft diameter |
| | | 107 | CS-M22430-I14 | 3.0 | CS-D507E | AC servo flange |
| | NEMA 24 | 147 | CS-M22430B-I14 | 3.0 | CS-D507E | AC servo flange, Brake |
| 109 | | CS-M22445-S | 4.5 | CS-D1008E | 1/2-inch shaft diameter | |
| NEMA 34 | 127 | CS-M23480-S | 8.0 | CS-D1008E | 1/2-inch shaft diameter | |
| | 147 | CS-M23485-S | 8.5 | CS-D1008E | 1/2-inch shaft diameter | |

Stepper Drives

| Series | Model | Matched Motor Series | Command Source | | | | Electrical Parameters | | | Motion Function Features | | | | | | I/O | | Encoder Resolution (ppr) | Mechanical Size (mm) | Others | |
|---------|--------------|----------------------|----------------|----------|--------------|---------|-----------------------|----------|----------------|--------------------------|--------------|-----------------|-------------|----------|---------------------------|---------------|----------------|--------------------------|----------------------|------------------|-----------------|
| | | | EtherNet/IP | EtherCAT | RS485 Modbus | Pul&Dir | CW&CCW | Power | Output Current | Logical Voltage | Alarm Output | Brake Self Test | Fault Reset | Z Signal | Open/Close Loop Selection | Digital Input | Digital Output | | | Tuning Cable | Tuning Software |
| 2CS3EIP | 2CS3EIP-D503 | CM Series | √ | | | | 20-50VDC | 0.5-2.2A | 12-24V | | √ | √ | √ | √ | √ | 2*4 | 2*2 | 1000/5000 | 155*116.5*28 | CABLE-USB1M5 | Motion Studio |
| | 2CS3EIP-D507 | | √ | | | | 20-50VDC | 1.0-7.0A | 12-24V | | √ | √ | √ | √ | √ | 2*4 | 2*2 | 155*116.5*28 | | | |
| 2CS3E | 2CS3E-D503 | | | √ | | | 20-50VDC | 0.5-2.2A | 12-24V | | √ | √ | √ | √ | √ | 2*4 | 2*2 | 155*116.5*28 | | | |
| | 2CS3E-D507 | | | √ | | | 20-50VDC | 1.0-7.0A | 12-24V | | √ | √ | √ | √ | √ | 2*4 | 2*2 | 155*116.5*28 | | | |
| CS3E | CS3E-D503B | | | √ | | | 20-50VDC | 0.1-3.0A | 12-24V | | √ | √ | √ | √ | √ | 6 | 2 | 118*90*28 | CABLE-TYPEC2M0 | | |
| | CS3E-D507B | | | √ | | | 20-50VDC | 0.1-7.0A | 12-24V | | √ | √ | √ | √ | √ | 6 | 2 | 118*90*28 | | | |
| | CS3E-D1008 | | | √ | | | 18-80VAC 30-110VDC | 0.5-8.0A | 12-24V | | √ | √ | √ | √ | √ | 7 | 7 | 151*113*40 | CABLE-MUSB1M5 | | |
| CS2RS | CS2RS-D503 | | | | √ | | 20-50VDC | 0.3-3.0A | 12-24V | | √ | √ | √ | √ | √ | 7 | 3 | 118*79.5*25.5 | CABLE-PC-1 | | |
| | CS2RS-D507 | | | | √ | | 20-50VDC | 0.5-7.0A | 12-24V | | √ | √ | √ | √ | √ | 7 | 3 | 118*79.5*25.5 | | | |
| | CS2RS-D1008 | | | | √ | | 18-80VAC 30-110VDC | 0.5-8.0A | 12-24V | | √ | √ | √ | √ | √ | 7 | 3 | 151*97*53 | | | |
| CS1 | CS1-D503S | | | | √ | √ | 20-50VDC | 0.5-3.0A | 5/24V | | √ | √ | √ | √ | √ | 4 | 6 | 118*79.5*25.5 | | | |
| | CS1-D507S | | | | √ | √ | 20-50VDC | 0.5-7.0A | 5/24V | | √ | √ | √ | √ | √ | 4 | 6 | 118*79.5*25.5 | | | |
| | CS1-D728S | | | | √ | √ | 20-72VDC | 0.5-8.0A | 5/24V | | √ | √ | √ | √ | √ | 4 | 6 | 118*79.5*25.5 | | | |
| CS | CS-D403 | | | | √ | √ | 20-50VDC | 0.3-3.0A | 5V | | √ | √ | √ | √ | √ | 3 | 1 | 116*69.2*26.5 | CABLE-PC | ProTuner CS_V3.0 | |
| | CS-D508 | | | | √ | √ | 20-50VDC | 0.5-7.0A | 5V | | √ | √ | √ | √ | √ | 3 | 1 | 116*69.2*26.5 | | | |
| | CS-D808 | | | | √ | √ | 20-80VDC | 0.5-8.0A | 5V | | √ | √ | √ | √ | √ | 3 | 1 | 151*97*53 | | | |
| | CS-D1008 | | | | √ | √ | 18-80VAC 30-110VDC | 0.5-8.0A | 5V | | √ | √ | √ | √ | √ | 3 | 1 | 151*97*53 | | | |
| | CS-D507E | | | | √ | √ | 20-50VDC | 0.5-7.0A | 5/24V | | √ | √ | √ | √ | √ | 3 | 2 | 116*69.2*26.5 | CABLE-PC-1 | Motion Studio | |
| | CS-D1008E | | | | √ | √ | 18-80VAC 30-110VDC | 0.5-8.0A | 5/24V | | √ | √ | √ | √ | √ | 3 | 2 | 151*97*53 | | | |

Integrated Stepper Motors

| Series | Model | Frame Size | Motor Type | Length (mm) | Holding Torque (mm) | Control Type | | | | Electrical Parameters | | | Motion Function Features | | | I/O | | Others | |
|------------|------------|------------|------------|-------------|--|--------------|-----------|----------|----------|-----------------------|----------------|-----------------|--------------------------|---------|------------------|---------------|----------------|---------------|-----------------|
| | | | | | | RS485 Modbus | Pulse&Dir | CW&CCW | | Power Voltage | Output Current | Logical Voltage | Alarm Output | PR Mode | I/O Configurable | Digital Input | Digital Output | Tuning Cable | Tuning Software |
| iEM | iEM-1703 | NEMA17 | Open Loop | 64 | 0.3 | | √ | | 20-36VDC | 0.3-3.0A | 5V | √ | | | 3 | 1 | CABLE-PC-1 | Motion Studio | |
| | iEM-1706 | | | 72 | 0.6 | | √ | | 20-36VDC | 0.3-3.0A | 5V | √ | | | 3 | 1 | | | |
| | iEM-1708 | | | 85 | 0.8 | | √ | | 20-36VDC | 0.3-3.0A | 5V | √ | | | 3 | 1 | | | |
| | iEM-RS1706 | | | 73 | 0.6 | √ | | | 20-36VDC | 0.3-3.0A | 12-24V | √ | √ | | 3 | 1 | | | |
| | iEM-RS1708 | | | 86 | 0.8 | √ | | | 20-36VDC | 0.3-3.0A | 12-24V | √ | √ | | 3 | 1 | | | |
| | iEM-2313 | NEMA23 | | 75 | 1.3 | | √ | √ | 20-50VDC | 0.5-6.0A | 5V | √ | | | 3 | 1 | | | |
| | iEM-2323 | | | 96 | 2.3 | | √ | √ | 20-50VDC | 0.5-7.0A | 5V | √ | | | 3 | 1 | | | |
| | iEM-2321-L | | | 89 | 2.1 | | √ | √ | 20-50VDC | 0.5-7.0A | 5V | √ | | | 3 | 1 | | | |
| | iEM-2331-L | | | 109 | 3.1 | | √ | √ | 20-50VDC | 0.5-7.0A | 5V | √ | | | 3 | 1 | | | |
| | iEM-RS2313 | | | 78 | 1.3 | √ | | | 20-50VDC | 0.5-6.0A | 12-24V | √ | √ | | 3 | 1 | | | |
| | iEM-RS2323 | 99 | | 2.3 | √ | | | 20-50VDC | 0.5-7.0A | 12-24V | √ | √ | | 3 | 1 | | | | |
| | iEM-2430 | NEMA24 | | 109 | 3.0 | | √ | √ | 20-50VDC | 0.5-7.0A | 5V | √ | | | 3 | 1 | | | |
| | iEM-2435 | | | 122 | 3.5 | | √ | √ | 20-50VDC | 0.5-7.0A | 5V | √ | | | 3 | 1 | | | |
| | iCS | iCS-1703 | | NEMA17 | Closed Loop (14-bit magnetic encoder) | 64 | 0.3 | | √ | | 20-36VDC | 0.3-3.0A | 5V | √ | | √ | | | 3 |
| iCS-1706 | | 72 | 0.6 | | | | √ | | 20-36VDC | 0.3-3.0A | 5V | √ | | √ | 3 | 1 | | | |
| iCS-1708 | | 85 | 0.8 | | | | √ | | 20-36VDC | 0.3-3.0A | 5V | √ | | √ | 3 | 1 | | | |
| iCS-RS1706 | | 73 | 0.6 | | | √ | | | 20-36VDC | 0.3-3.0A | 12/24V | √ | √ | √ | 3 | 1 | | | |
| iCS-RS1708 | | 86 | 0.8 | | | √ | | | 20-36VDC | 0.3-3.0A | 12/24V | √ | √ | √ | 3 | 1 | | | |
| iCS-2313 | | NEMA23 | 75 | 1.3 | | | √ | √ | 20-50VDC | 0.5-6.0A | 5V | √ | | √ | 3 | 1 | | | |
| iCS-2323 | | | 96 | 2.3 | | | √ | √ | 20-50VDC | 0.5-7.0A | 5V | √ | | √ | 3 | 1 | | | |
| iCS-2321-L | | | 89 | 2.1 | | | √ | √ | 20-50VDC | 0.5-7.0A | 5V | √ | | √ | 3 | 1 | | | |
| iCS-2331-L | | | 109 | 3.1 | | | √ | √ | 20-50VDC | 0.5-7.0A | 5V | √ | | √ | 3 | 1 | | | |
| iCS-RS2313 | | | 78 | 1.3 | | √ | | | 20-50VDC | 0.5-7.0A | 12/24V | √ | √ | √ | 3 | 1 | | | |
| iCS-RS2323 | | 99 | 2.3 | √ | | | | 20-50VDC | 0.5-7.0A | 12/24V | √ | √ | √ | 3 | 1 | | | | |
| iCS-2430 | | NEMA24 | 109 | 3.0 | | | √ | √ | 20-50VDC | 0.5-7.0A | 5V | √ | | √ | 3 | 1 | | | |
| iCS-2435 | | | 122 | 3.5 | | | √ | √ | 20-50VDC | 0.5-7.0A | 5V | √ | | √ | 3 | 1 | | | |

Typical Industry Application

Electronic Manufacturing Equipment

We provide accurate bus-based and intelligent motion control solutions for electronic equipment to help customers improve production efficiency and reduce costs

- Dispensing machine
- SMT
- Screw locking machine
- Wire stripping machine
- Lithium battery equipment



Dispensing machine

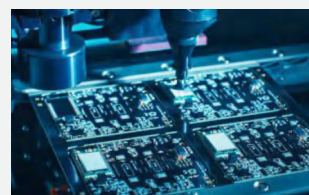

SMT



Screw locking machine



Wire stripping machine

Laser Engraving Equipment

For engraving equipment, especially for non-linear multi-dimensional plane processing, we can improve the responsiveness of feedback through large bandwidth response frequency, no horizontal and vertical stripes are produced, the chamfer is more flexible, and the processing surface is smoother.

- Laser cutting machine
- Laser marking machine
- Jade carving machine
- Wood carving machine



Laser cutting machine



Wood carving machine



Laser marking machine



Renewable Energy Equipment

Through the high-speed and high-response servo stepper system to drive silicon wafers, batteries and other automatic production and inspection modules, it contributes to improving the production efficiency of the whole line of new energy equipment and reducing production costs for customers.

- Sorter
- Stack welding machine
- Liquid injection machine



Stack welding machine



Sorter



Liquid injection machine

Textile and Garment Equipment

We support multi-variety production and high quality demands in the textile and garment industry, contributing to the consistency of quality and high production efficiency of textile and garment.

- Computer cutting plotter
- Template cutting machine
- Garment proofing machines
- Pattern cutting machine
- Vertical cutting machine



Textile Equipment

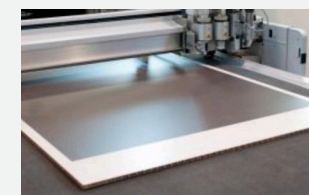

Template cutting machine



Garment proofing machines

Medical and Health Equipment

Excellent low vibration, low noise and low heat generation make the medical equipment run quietly and smoothly.

- Biochemical analyzer
- Peristaltic pump
- Mask machine
- Blood sample analyzer
- Urine analyzer



Blood sample analyzer



Biochemical analyzer



Peristaltic pump



Mask machine

Product Overview

Fieldbus Stepper Drives

2EM3EIP Series (NEW)
2EM3E Series (NEW)
EM3E Series
EM2RS Series

EtherNet/IP **EtherCAT** **Modbus**

Power Voltage:
20-50VDC, 20-80VDC
30-110VDC or 20-80VAC

Command Source:
EtherCAT, EtherNet/IP, Modbus RTU

Inputs and Outputs:
EM3E-522E/556E/870E: 5 DI, 2 DO
EM3E-A882: 7 DI, 6 DO
2EM3E Series: Dual-axis, 4 DI, 2 DO
2EM3EIP Series: Dual-axis, 4 DI, 2 DO

Pulse Control Stepper Drives

EM Series (NEW)
DM Series
EM1 Series (NEW)

Power Voltage:
12-40VDC, 20-50VDC, 20-80VDC, 30-110VDC or
20-80VAC, 110VAC+10%, 220VAC+10%

Command Source:
EM-S: Pulse&Direction, CW&CCW
DM-E: Pulse&Direction
EM1: Pulse&Direction, CW&CCW

Inputs and Outputs:
DM332E/322E: 3 DI
DM542E/556E: 3 DI, 1 DO
DMA860E: 3 DI, 2 DO
EM1: 3 DI, 2 DO
DM1182/DM2282: 3 DI
3DM580S/883/2283: 3 DI
EM-S: 3 DI, 1 DO

5-phase Stepper Drives

DM5 Series (NEW)
DM5-EC series (NEW)

EtherCAT

Power Voltage:
24-36VDC 20-50VDC

Command Source:
DM5: Pulse&Direction
DM5-EC: EtherCAT

Inputs and Outputs:
DM5: 4DI 3DO
DM5-EC: 5DI 2DO

Standard Stepper Motors

CM Series
5-phase stepper motor

Frame Size:
From NEMA 08(20mm) to NEMA 51(130mm)
2-phase: 20mm, 28mm, 35mm, 42mm, 57mm, 60mm, 86mm, 110mm, 130mm
3-phase: 57mm, 86mm, 110mm

Options:
Dual shaft
Encoder
Brake
IP65 waterproof
Gearbox

Fieldbus Closed Loop Stepper Drives

2CS3EIP Series (NEW)
2CS3E Series (NEW)
CS3E Series
CS2RS Series

EtherNet/IP **EtherCAT** **Modbus**

Power Voltage:
20-50VDC
30-110VDC or 20-80VAC

Command Source:
EtherCAT, EtherNet/IP, Modbus RTU

Inputs and Outputs:
CS3E-D503/507/1008: 7 DI / 7 DO
CS2RS-D503/507/1008: 7 DI, 3 DO
2CS3E series: Dual-axis, 4 DI, 2 DO
2CS3EIP series: Dual-axis, 4 DI, 2 DO

Pulse Control Closed Loop Stepper Drives

CS1 Series
CS Series

Power Voltage:
20-50VDC
20-72VDC
20-80VAC or 30-110VDC

Command Source:
Pulse&Direction, CW&CCW

Inputs and Outputs:
CS1-D507S: 4 DI, 3 DO encoder outputs
CS1-D728S: 4 DI, 3 DO
CS-D507E: 3 DI, 2 DO
CS-D1008E: 3 DI, 2 DO

Closed Loop Stepper Motors

CS-M Series & ES2-MH Series

Frame Size and Encoder:
20mm: 1000 line 28mm: 1000 line
42mm: 1000/5000 line
57mm: 1000/5000 line
60mm: 1000/5000 line
86mm: 1000/5000 line
110mm: 1000/5000 line

Options:
Brake
IP65 waterproof

Integrated Stepper Motors



Open loop: iEM Series iEM-RS Series

Closed loop: iCS Series iCS-RS Series



Power Voltage:
20-36VDC 20-50VDC

Command Source:
iEM/iCS: Pulse&Direction
iEM-RS/iCS-RS: Modbus RS485

Inputs and Outputs:
3 DI, 1 DO

Power Supplies

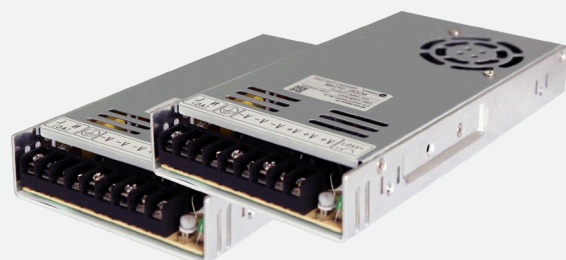

LSP Series

Power Voltage:
220VAC±10% or 110VAC±10% input
260W: 24VDC output
360W: 24VDC/36VDC/48VDC output
400W: 60VDC output

Gearboxes

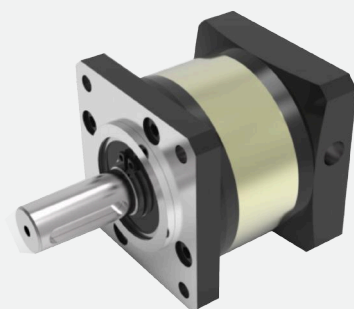

PLF Series

Gearboxes:
60mm: 3:1, 5:1, 7:1, 10:1
90mm: 3:1, 5:1, 7:1, 10:1
NEMA 23 and 34 1 to 2 stages High precision Low noise

Stepper Drive Part Numbers

EM □ □ 5 56 S - □

| Series Name | |
|-------------|----------------------|
| EM | New Series |
| DM | Classical Series |
| 3DM | 3-phase Drive Series |

| Control Mode | |
|--------------|------------------|
| 3E- | EtherCAT Control |
| 2RS- | RS485 Modbus RTU |
| Blank | Pulse Control |

| AC or DC | |
|----------|-------------------------------|
| Blank | DC |
| A | AC (except DM1182 and DM2282) |

| Max Power Voltage | |
|-------------------|---------|
| 4 | 40V |
| 5 | 50V |
| 8 | 80V |
| 11 | 110V±10 |
| 8 | % |
| | 120V±10 |
| | % |

| Special Control | |
|-----------------|---|
| IO | 5-24V Digital Input Control |
| IO-24 | 24V Digital Input Control |
| V-24 | 0-10V Analog and 24V Digital Input Control |
| AI | 0-5V Analog Input Control or Pulse Control |
| 500 CAN | Max Pulse Frequency 500KHz CANopen Control |

| Grade | |
|-------|------------------|
| Blank | Standard |
| E | Economic |
| S | High Performance |

| Max Peak Current | |
|------------------|--------|
| 15:1.5 | 56:5.6 |
| A | A |
| 22:2.2 | 70:7.0 |
| A | A |
| 32:3.2 | 82:8.2 |
| A | A |
| 42:4.2 | 83:8.3 |
| A | A |

Stepper Motor Part Numbers

57 CM 23 - 4A - □ □

| Series Name | |
|--------------------|----------------------|
| 2020mm (NEMA 8) | 2828mm (NEMA 11) |
| 3535mm (NEMA 14) | 3939mm (NEMA 16) |
| 4242mm (NEMA 17) | 57/D5757mm (NEMA 23) |
| 6060mm (NEMA 51) | 8686mm (NEMA 34) |
| 110110mm (NEMA 17) | 130130mm (NEMA 42) |

| Series Name | |
|-------------|--------------------------------|
| CM | New 2-phase Motor Series |
| HS | Classical 2-phase Motor Series |
| 3S | 3-phase Motor Series |

| Holding Torque | |
|----------------|-----------|
| 013:0.13N.m | 30:3.0N.m |
| 02:0.2N.m | 45:4.5N.m |
| 06:0.6N.m | 80:8.0N.m |
| 08:0.8N.m | 85:8.5N.m |
| 13:1.3N.m | 120:12N.m |
| 23:2.3N.m | |
| For NEMA 42&51 | |
| 12:12N.m | 28:28N.m |
| 20:20N.m | m |
| 27:27N.m | 45:45N.m |
| | m |

| Customized | |
|------------|------------------|
| | Customized Model |

| Standard Customized Specification | |
|-----------------------------------|-----------------------------|
| Blank | Standard |
| BZ | Brake |
| SZ | Dual Shaft |
| FS | Waterproof (Rate IP65) |
| I | Shaft Diameter |
| K | NEMA23 Motor Shaft with Key |
| S30 | Shaft Length 30mm |
| CZ | Plug-in Type Motor |
| ZK | Hollow Shaft Motor |
| Rd05 | Integrated 1:5 Gearbox |
| Rd10 | Integrated 1:10 Gearbox |
| Rd20 | Integrated 1:20 Gearbox |

| Rated Current | |
|---------------|------------------------|
| Blank | Standard Rated Current |
| 1A | 1.5 |
| 3A | A |
| 4A | 3.0 |
| | A |
| | 4.0 |
| | A |



2EM3EIP Series \ 2EM3E Series

Fieldbus Stepper Drives

- Support EtherCAT(EtherNet/IP) fieldbus
- Matching most of master controller

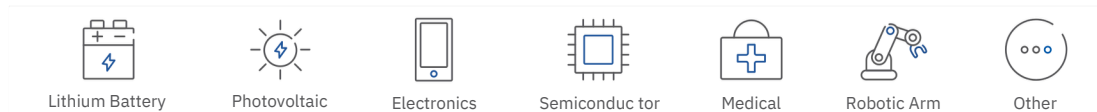

Overview

○ EtherCAT(EtherNet/IP) Communication

- Support EtherNet/IP(EtherCAT) communication.
- Support great majority of master station such as Beckhoff, Omron, KEYENCE, Panasonic etc.
- Support position, velocity, and homing control mode.

○ More Efficient by Dual-axis Control

- One drive controls two axes via one IP address, highly reduce communication load rate.
- Two axes are independently controlled.

○ STO Optional

- Safe torque off (STO) ensure the safety system.

○ Saving Cost

- One dual-axis drive is more economic than two single-axis drives.

○ Saving Mounting Space

- 10% thickness reducing compared to one single-axis drive.
- 50% at least mounting space saving compared to two single-axis drives.

Specifications

| Models | Operating Voltage | Output Current (A) | Matching Motor | Weight (kg) | Dimension (mm) |
|----------------------|--|--------------------|----------------|-------------|----------------|
| 2EM3EIP -522 | 20-50VDC | 0.5-2.2 | NEMA8/11/14/17 | 0.4 | 155*116.5*2 |
| 2EM3EIP -556 | 20-50VDC | 1.0-5.6 | NEMA17/23/24 | 0.4 | 8 |
| 2EM3EIP -870 | 20-80VDC | 1.0-7.0 | NEMA23/24/34 | 0.4 | 155*116.5*2 |
| 2EM3E-522 | 20-50VDC | 0.5-2.2 | NEMA8/11/14/17 | 0.4 | 8 |
| 2EM3E-556 | 20-50VDC | 1.0-5.6 | NEMA17/23/24 | 0.4 | 155*116.5*2 |
| 2EM3E-870 | 20-80VDC | 1.0-7.0 | NEMA23/24/34 | 0.4 | 8 |
| Termination Resistor | The last node needs to add the terminal resistance generally | | | | 155*116.5*2 |
| Tuning cable | CABLE-USB1M5 | | | | 8 |
| CABLE-TX*M*-BUS | Network Cable: 0.1m, 0.2m, 0.3m, 0.4m, 1m, 1.5m, 2m, 3m,5m,7m, 10m,15m,20m | | | | 155*116.5*2 |

8

155*116.5*2

8

2EM3EIP Series \ 2EM3E Series

Unit: mm

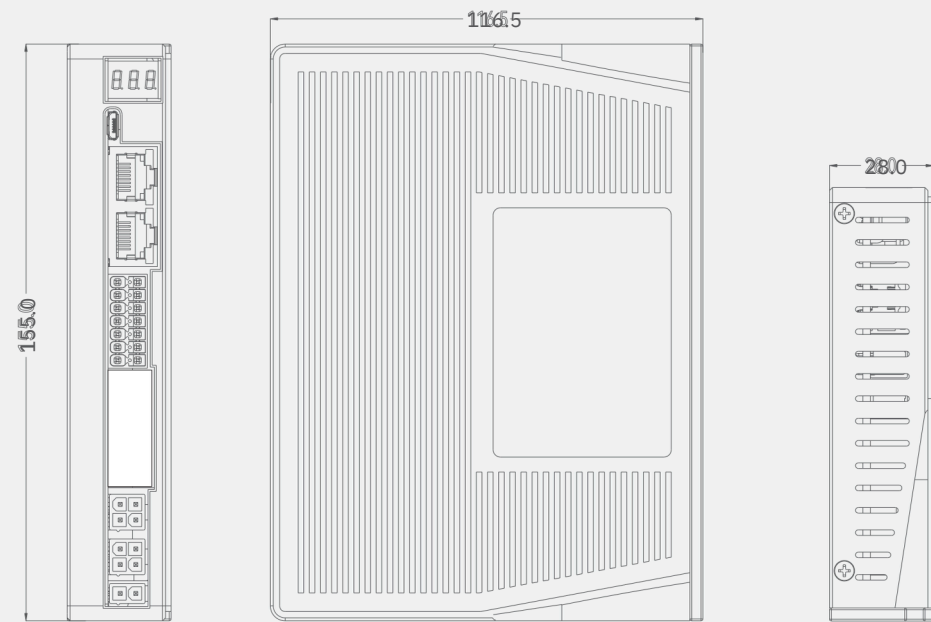

Drive Wiring Diagram

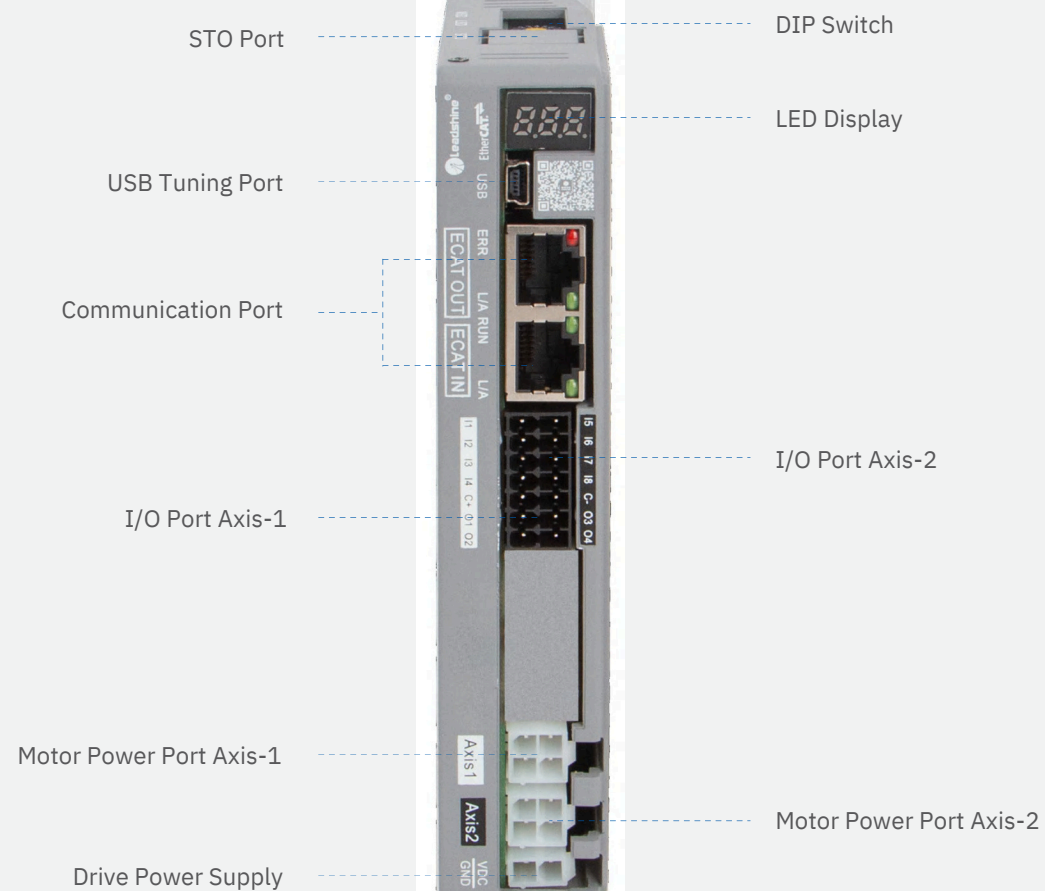
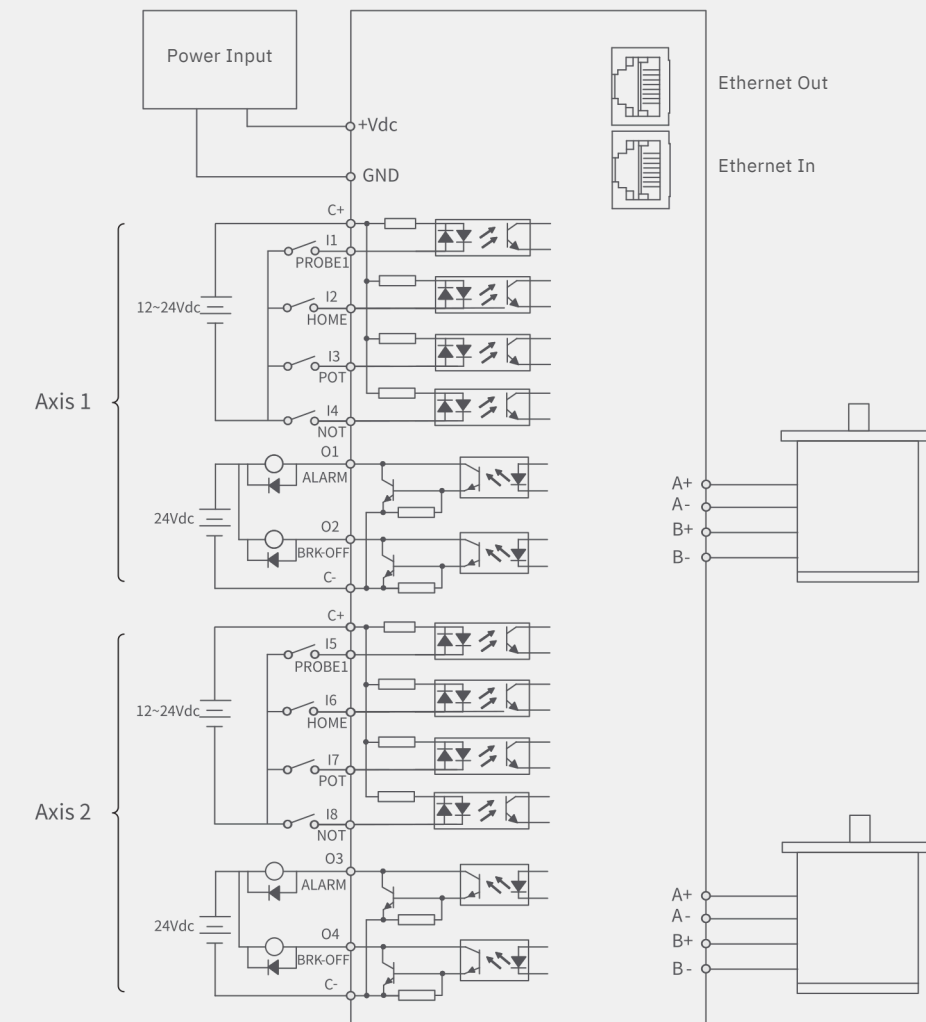



EM3E Series

Fieldbus Stepper Drives

EM3E series drives support operating modes: Profile Position (PP), Profile Velocity (PV), Homing(HM), Cyclic Synchronous Position (CSP). The products can be matched with most of EtherCAT controller/PLC such as Beckhoff, Omron, Trio, etc.

- Support CoE control and CiA 402 protocol
- Matching most of master controller
- Conformance tested by ETG

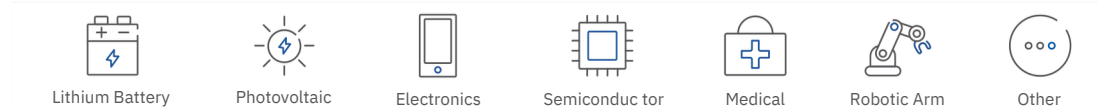

Overview

- Thickness reduce to 28mm, more benefit for mounting.
- Configurable I/O features: limit switch, alarm, brake, etc.
- Friendly type-C tuning port
Improve network anti-interference ability.
- Optically coupled isolated input, strong anti-interference ability.
- Low noise and vibration, smooth motion.
- Auto-tuning of motor parameters.
- EM3E support standard EtherCAT with operation modes of PP, PV, CSP, HM.
- Protections for over voltage, over current etc.

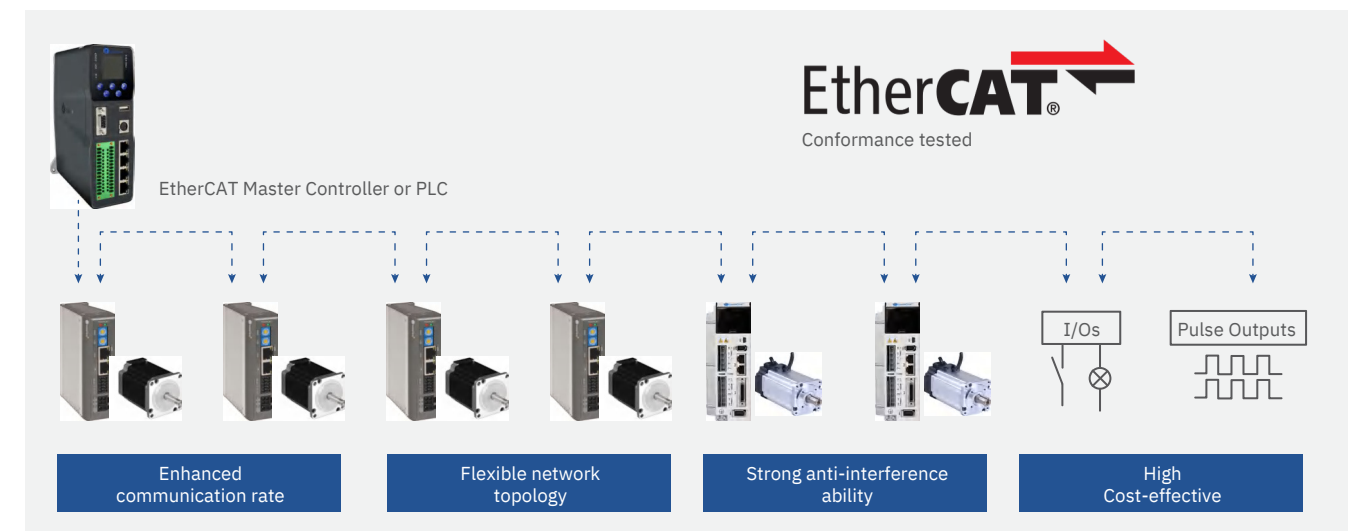

Specifications

| Models | Operating Voltage | Output Current (A) | Matching Motor | Weight (kg) | Dimension (mm) |
|-----------------|--|--------------------|----------------|-------------|----------------|
| EM3E-522B | 20-50VDC | 0.3-2.2A | NEMA8/11/14/17 | 0.57 | 118*90*28 |
| EM3E-556B | 20-50VDC | 1.0-5.6A | NEMA17/23/24 | 0.57 | 118*90*28 |
| EM3E-570B | 20-50VDC | 1.0-7.0A | NEMA23/24/34 | 0.57 | 118*90*28 |
| EM3E-A882 | 20-80VAC or 30-100VDC | 2.1-8.0A | NEMA34 | 0.85 | 151*113*20 |
| Tuning Cable | CABLE-TYPEC2M0 | | | | |
| CABLE-TX*M*-BUS | Network Cable: 0.1m, 0.2m, 0.3m, 0.4m, 1m, 1.5m, 2m, 3m, 5m, 7m, 10m, 15m, 20m | | | | |

EM3E Series

Unit: mm

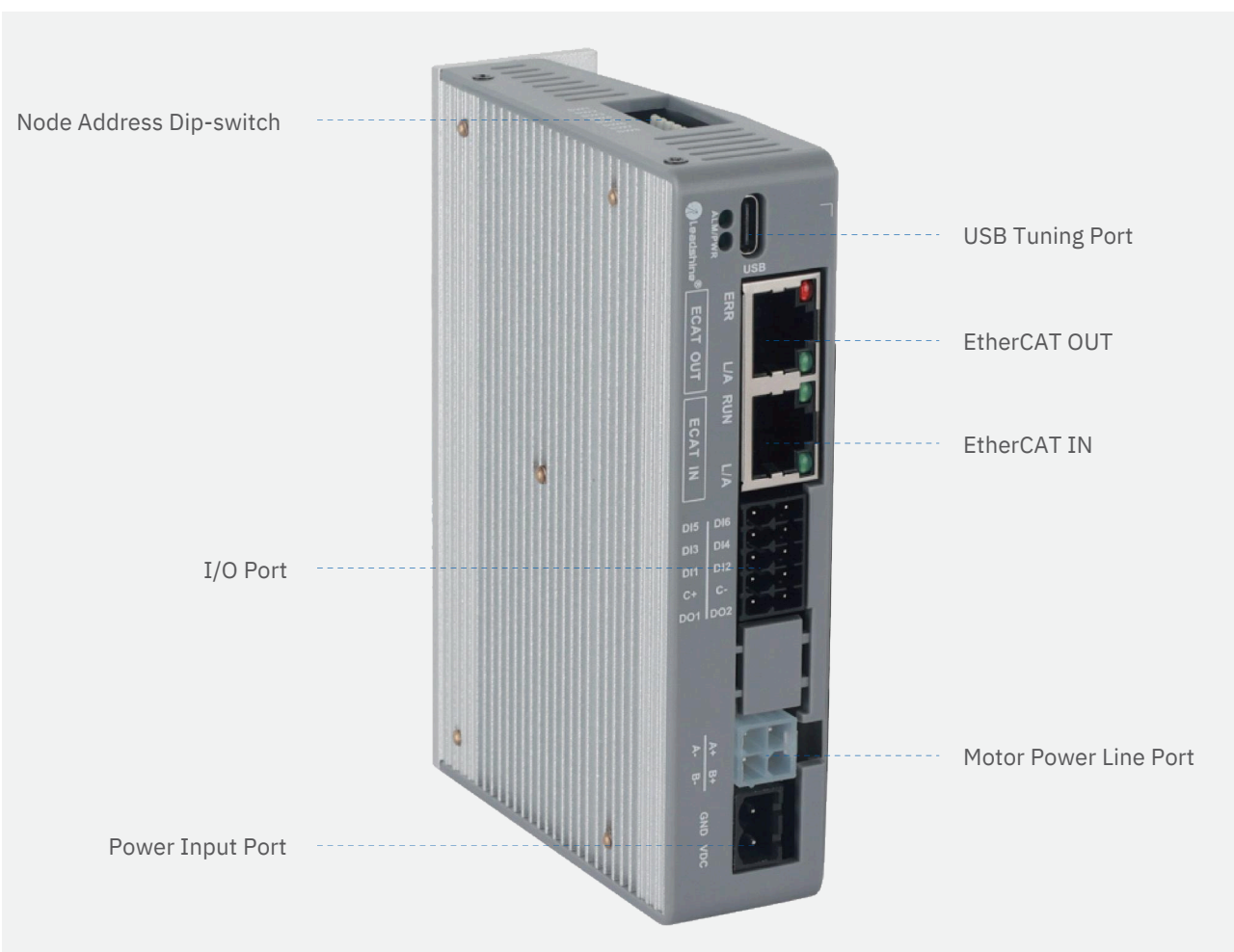
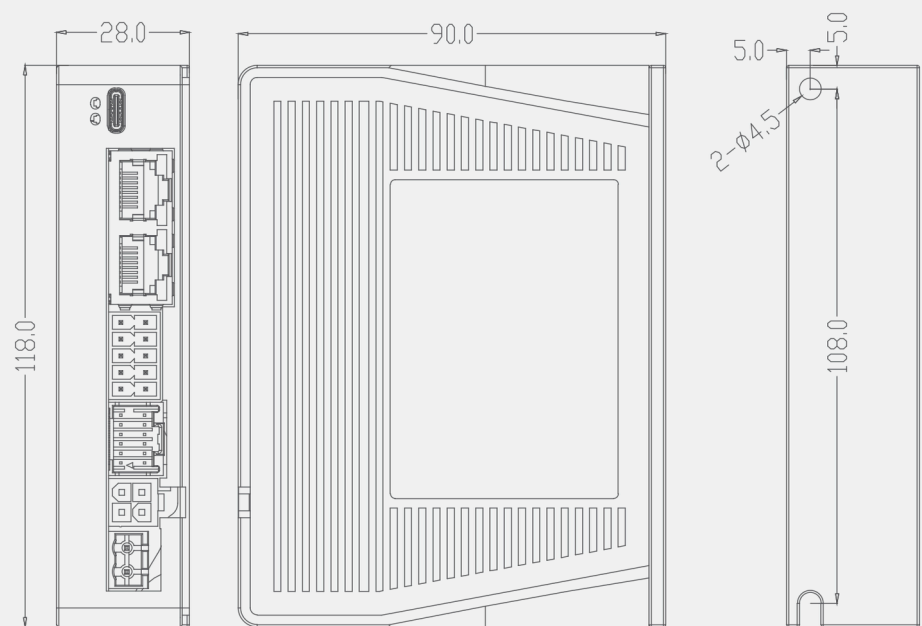

Drive Wiring Diagram

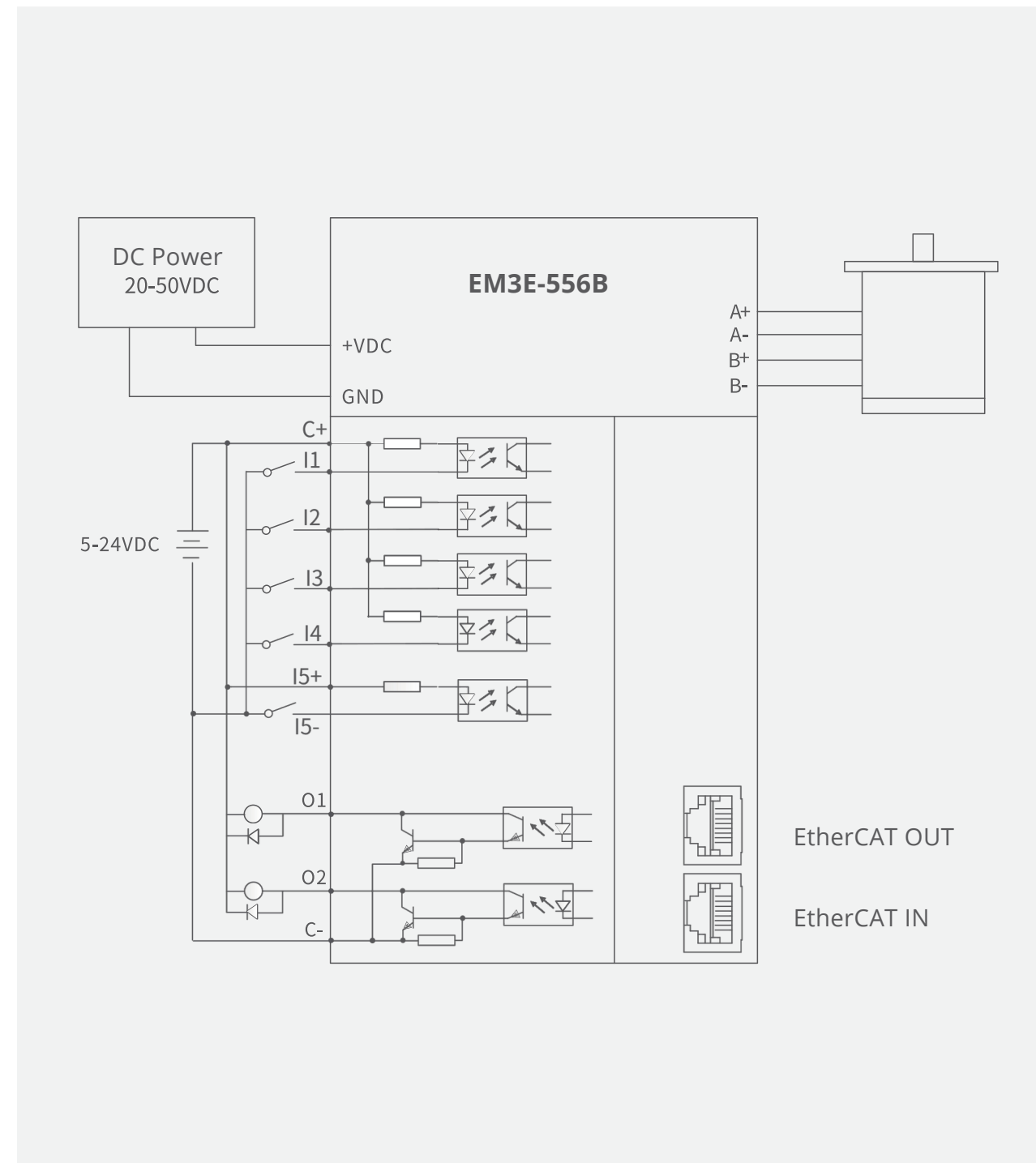



EM2RS Series

Fieldbus Stepper Drives

- Standard Isolated RS485 Modbus
- Smooth motion & Anti-resonance
- Built-in Uni-axial Control Instruction
- HMI, PLC or External I/O start motion

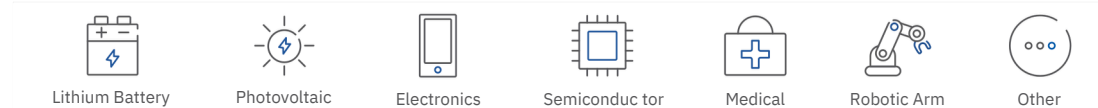

Overview

- **7 Programmable Inputs**
 - Limit + / - or Origin inputs
 - Quick stop, Alarm reset and Enable inputs
 - JOG + / - or Position Table inputs
- **3 Programmable Outputs**
 - Alarm, Brake outputs
 - Homing / Instruction / Path complete
- **Modes of Operation**
 - Velocity
 - Position
 - Homing
- **Support Functions**
 - Teaching Interrupt Skip,
 - Suspend, Circulate motion
 -
- **PC Software for Easy Setup, Fine Tune, Matching Motors**
 - NEMA8, 11,17, 23, 24, 34
 - Standard, dual shaft, brake, waterproof

Support RS485 communication

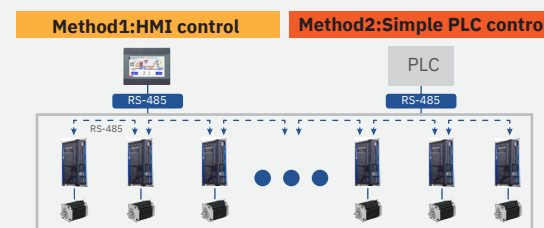

Built-in uni-axial control instruction

- Programmable 16-segment position table, support positioning / homing / limit / quick stop / JOG...

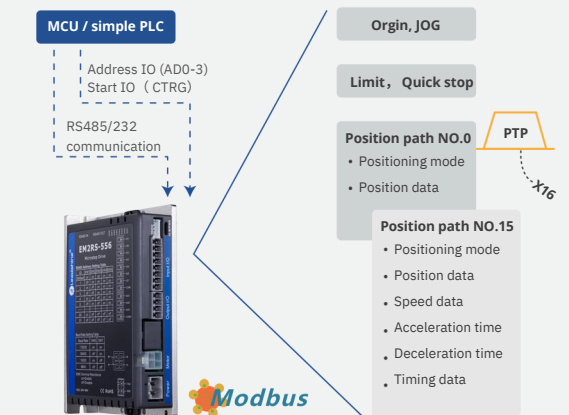

Instruction smoothing

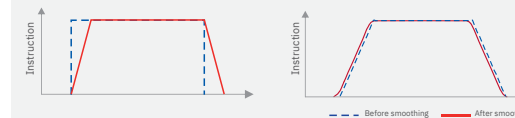

Figure A: When the controller sends a step signal of instruction, the stepper drive automatically smooth to a trapezoidal signal.

Figure B: When the controller sends a trapezoidal signal of instruction, the stepper drive automatically smooth to a s-shaped signal.

Specifications

| Models | Operating Voltage | Output Current (A) | Matching Motor | Weight (kg) | Dimension (mm) |
|-----------------|---|--------------------|----------------|-------------|----------------|
| EM2RS-522 | 20-50VDC | 0.3-2.2 | NEMA8/11/14/17 | 0.55 | 151*97*53 |
| EM2RS-556 | 20-50VDC | 0.5-5.6 | NEMA17/23/24 | 0.55 | 118*79.5*25.5 |
| EM2RS-870 | 20-80VDC | 0.5-7.0 | NEMA23/24/34 | 0.55 | 118*79.5*25.5 |
| EM2RS-A882 | 20-80VAC or 30-100VDC | 0.5-8.0 | NEMA24/34 | 0.57 | 155*116.5*28 |
| Tuning cable | CABLE-PC-1 | | | | |
| CABLE-TX*M*-BUS | Network Cable: 0.1m, 0.2m, 0.3m, 0.4m, 1m, 1.5m, 2m, 3m,5m,7m, 10m,15m, 20m | | | | |



EM-S Enhanced Version DM-E Cost-effective Version

Pulse Control Stepper Drives

EM-S Series Enhanced Performance

EM-S series stepper drives from Leadshine offer superior performance and exceptional high reliability. Based on Leadshine's 20+ years' experience in stepper motor control, they adopt the latest control technology and are ideal for modern machine manufactures. Not only inheriting features of smooth motion, low noise, low heating, etc. from past Leadshine stepper drives, they also offer new functions and features such as improved torque in all speed ranges, fault output, brake control, pulse command smoothing... They are capable of powering wide range of stepper motors of NEMA 8, 11, 15, 17, 23, 34, and 42.

Overview

- Torque increased by 10%-25%
- Step & DIR or CW & CCW control
- Alarm and Brake outputs
- 200kHz (500kHz optional) max frequency
- 5V or 24V signal voltage optional
- Soft-start with no "jump"
- Over-voltage, over-current

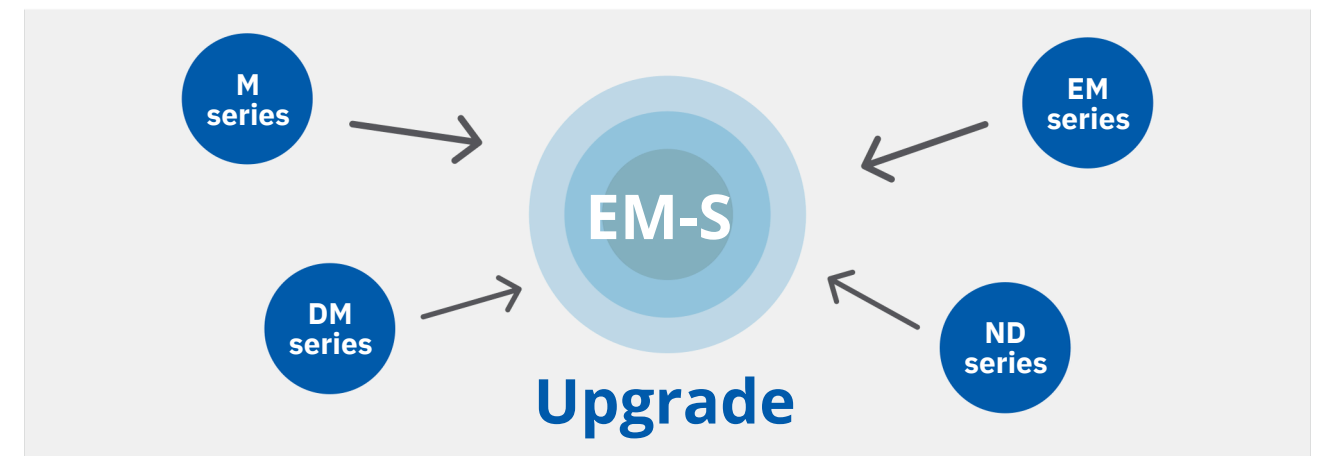

◦ Torque comparison (same condition)

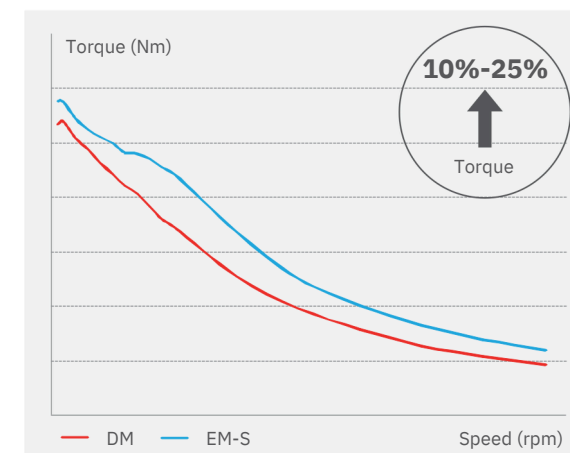

◦ Features of Second DIP Switch

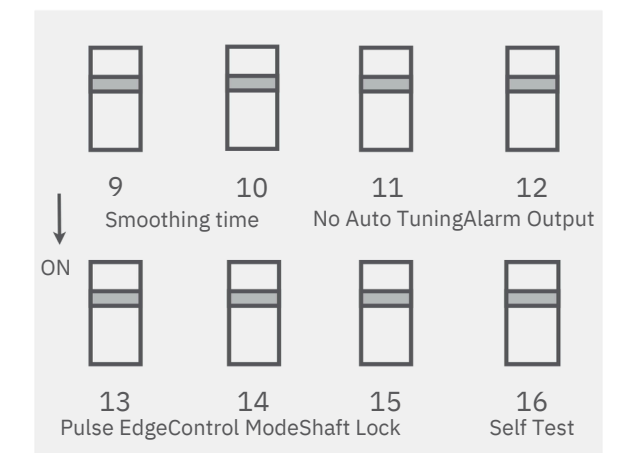

○ Pulse Smoothing Filter

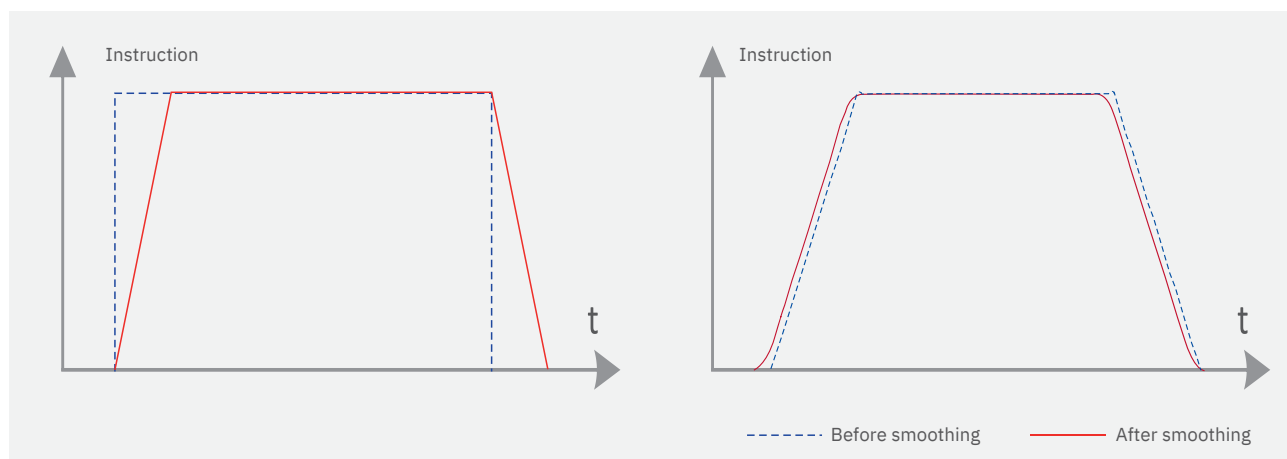

○ Alarm and Brake Outputs

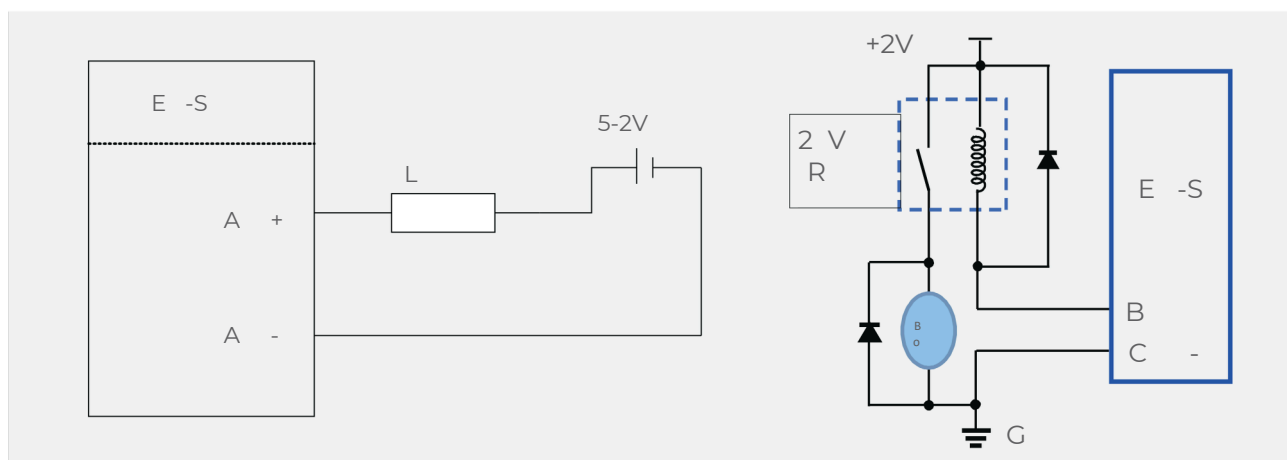

☰ Specifications

| Items | EM415S | | EM422S | | EM532MINI | | EM542S | | EM556S | | EM870S | | EM882S | |
|---------------------------|-----------------|-----|--------|-----|-----------|------|-----------|---------|-----------|-------------|--------------|---------|----------|-------------|
| | Min | Max | Min | Max | Min | Max | Min | Max | Min | Max | Min | Max | Min | Max |
| Output Current (A) | 0.3 | 1.5 | 0.3 | 22 | 30 | 24 | 0.5 | 4.2 | 0.5 | 4.2 | 0.5 | 7.0 | 0.5 | 8.2 |
| Power Voltage (VDC) | 12 | 40 | 12 | 40 | 18 | 50 | 20 | 50 | 20 | 50 | 20 | 80 | 20 | 80 |
| Max Input Frequency (kHz) | - | 70 | - | 70 | - | 1000 | - | 200 | - | 200 or 500* | - | 200 | - | 200 or 500* |
| Logical Current (mA) | 7 | 16 | 7 | 16 | 7 | 16 | 7 | 16 | 7 | 16 | 7 | 16 | 7 | 16 |
| Logical Voltage (VDC) | 0 | 5 | 0 | 5 | 0 | 5 | 0 | 5 or 24 | 0 | 5 or 24 | 0 | 5 or 24 | 0 | 5 |
| Min Pulse Width (us) | 7.5 | | 7.5 | | 0.5 | | 2.5 | | 2.5 or 1 | | 2.5 | | 2.5 or 1 | |
| Matched Motors Size | NEMA 8/11/14/17 | | NEMA17 | | NEMA17/23 | | NEMA17/23 | | NEMA23/24 | | NEMA23/24/34 | | NEMA34 | |

Note: (*) The drive with 500kHz is another model.

EM-S Series Interface and Dimensions

(unit: mm, 1 inch=25.4 mm)

EM532 MINI

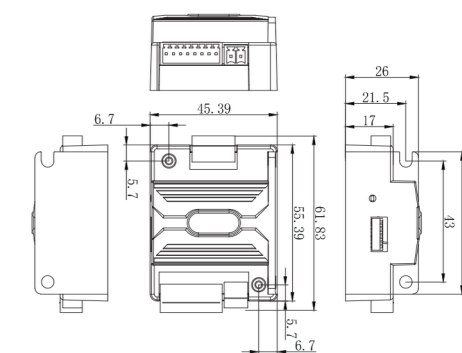
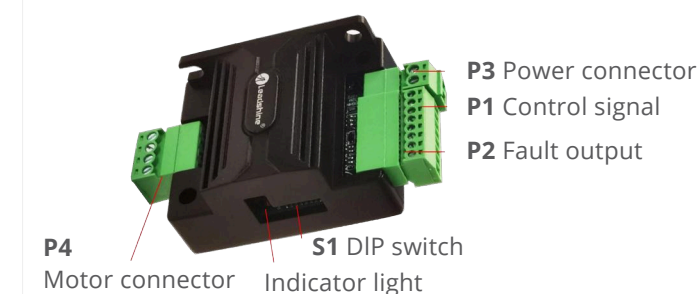

EM415S EM422S

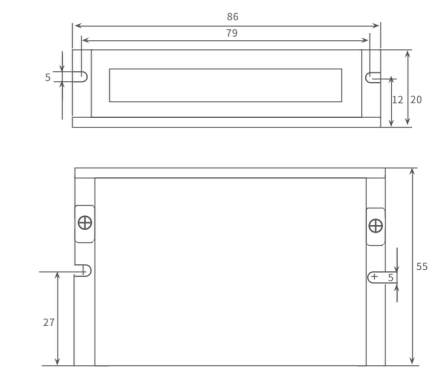
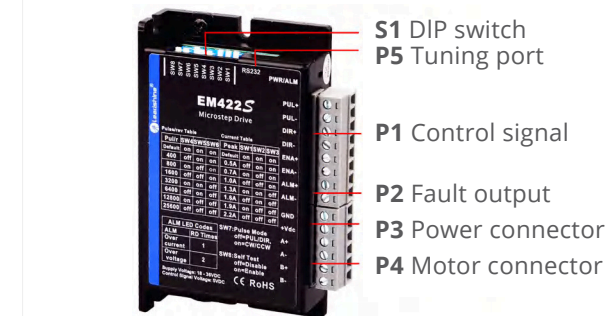

EM542S EM556S EM870S

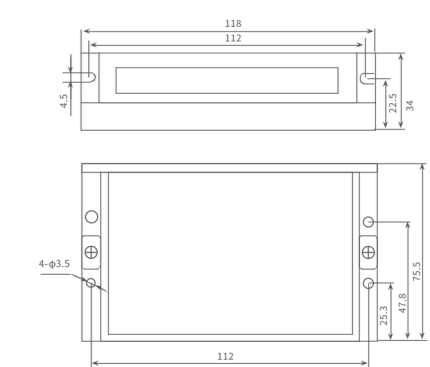
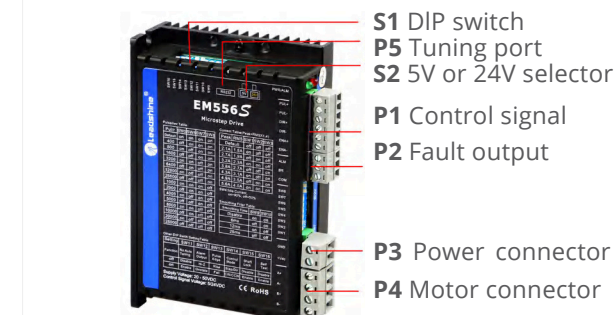

EM882S

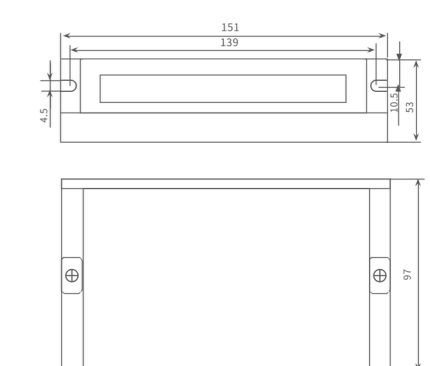
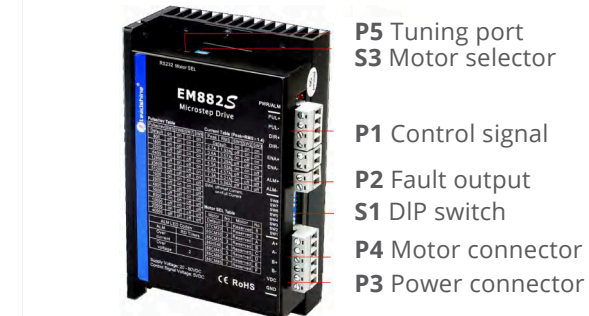

DM-E Series---Cost-effective

The DM-E series consists of stepper drives adopting Leadshine latest advanced stepper control technology. Those stepper drives are highly reliable with good performance and highly competitive cost. They can power a wide range of stepper motors from NEMA 8 to NEMA 34 (model dependent). DM-E stepper drives are easy to configure and setup. Output current and micro step resolution can be simply set up via DIP switches.



| DM322E | DM332E | DM542E | DM556E | DMA860E |
|-----------|-----------|-----------|-----------|--------------------------|
| 12-30 VDC | 12-30 VDC | 20-50 VDC | 20-50 VDC | 20-80 VAC/ 30-110 VDC |
| 0.3-2.2 A | 1.0-3.2 A | 1.0-4.2 A | 1.7-5.6 A | 2.4-7.2 A |

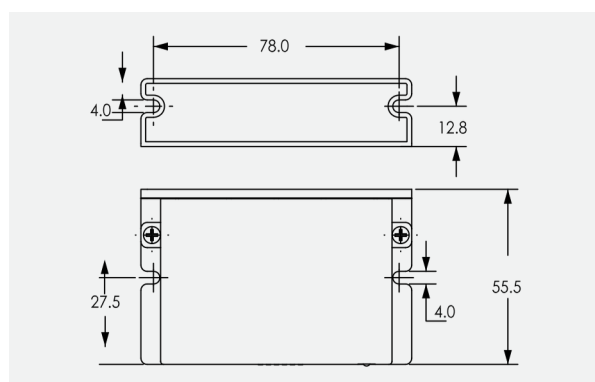

DM322E / DM332E

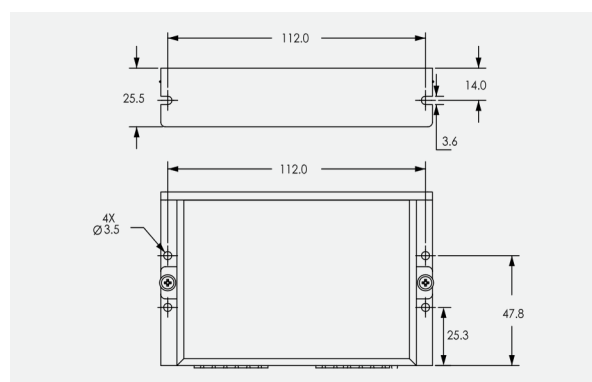

DM542E

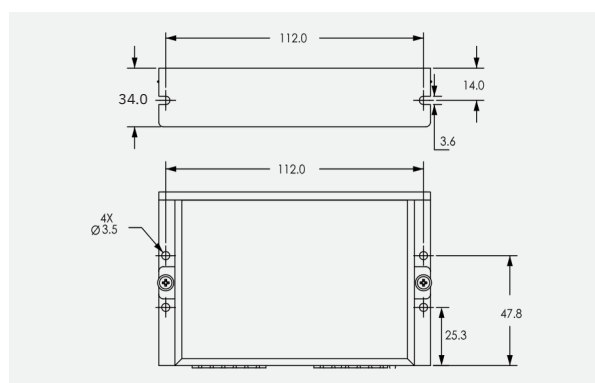

DM556E

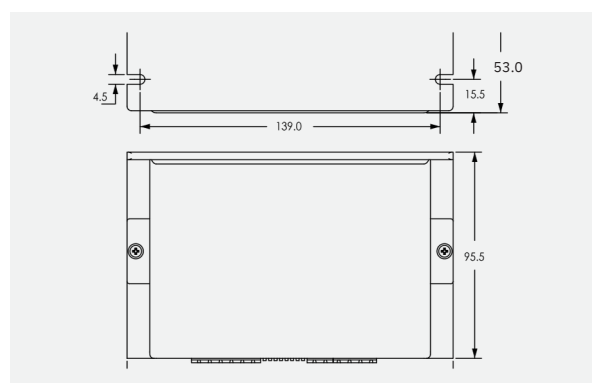

DMA860E

DM Series---AC Power Input

| Model | Phase | Power Voltage | Output Current(A) | Control Type | Logical Voltage(VDC) | Phase | Matched Motor Size |
|---------|-------|-------------------------|-------------------|------------------|----------------------|------------|--------------------|
| DMA860H | 2 | 20-80 VAC or 30-110 VDC | 2.4-7.2 | Step&Dir, CW&CCW | 5 | 151*97*48 | NEMA23/24/34 |
| DMA882S | 2 | 20-80 VAC or 30-110 VDC | 0.5-8.2 | Step&Dir, CW&CCW | 5 | 151*97*48 | NEMA23/24/34 |
| DM1182 | 2 | 70-130 VAC | 0.5-8.2 | Step&Dir, CW&CCW | 5 | 202*167*63 | NEMA34/42 |
| DM2282 | 2 | 180-240 VAC | 0.5-8.2 | Step&Dir, CW&CCW | 5 | 202*167*63 | NEMA34/42/53 |

DM Series---AC Power Input

| Model | Phase | Power Voltage | Output Current(A) | Control Type | Logical Voltage(VDC) | Phase | Matched Motor Size |
|---------|-------|---------------|-------------------|------------------|----------------------|------------|--------------------|
| 3DM580S | 3 | 20-50 VDC | 0.5-8.0 | Step&Dir, CW&CCW | 5 | 151*97*48 | NEMA17/23/24/34 |
| 3DM883 | 3 | 20-80 VDC | 2.2-8.3 | Step&Dir, CW&CCW | 5 | 151*97*48 | NEMA24/34 |
| 3DM2283 | 3 | 180-240 VAC | 2.2-11.7 | Step&Dir, CW&CCW | 5 | 202*167*63 | NEMA 34/42/53 |

Dimensions

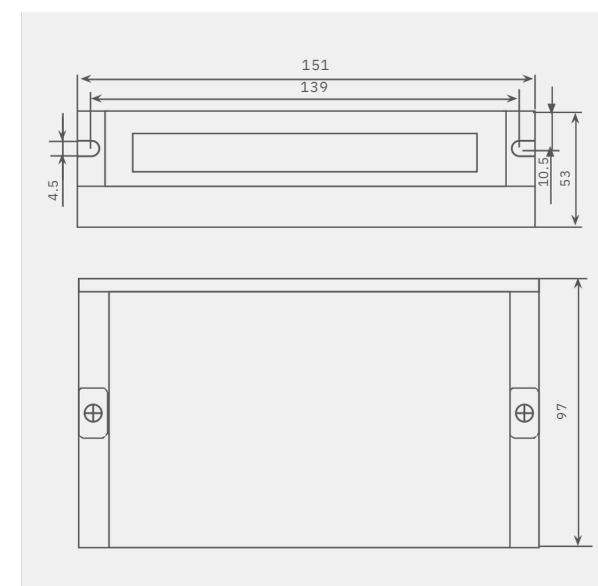

(a) Mechanical specifications of the DMA882S

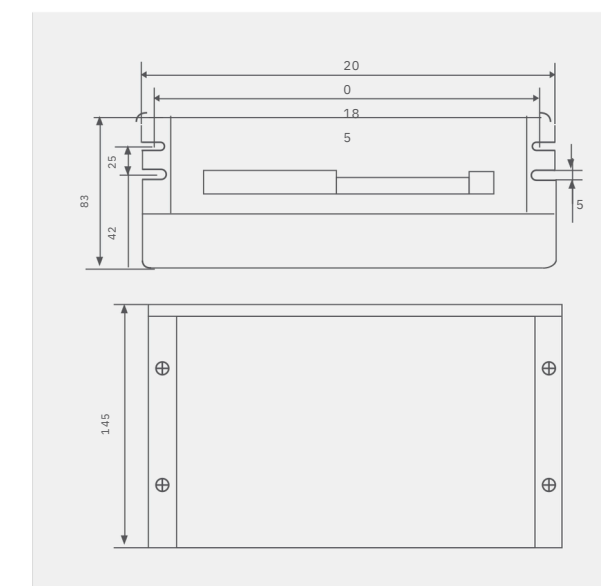

(b) Mechanical specifications of the DM1182

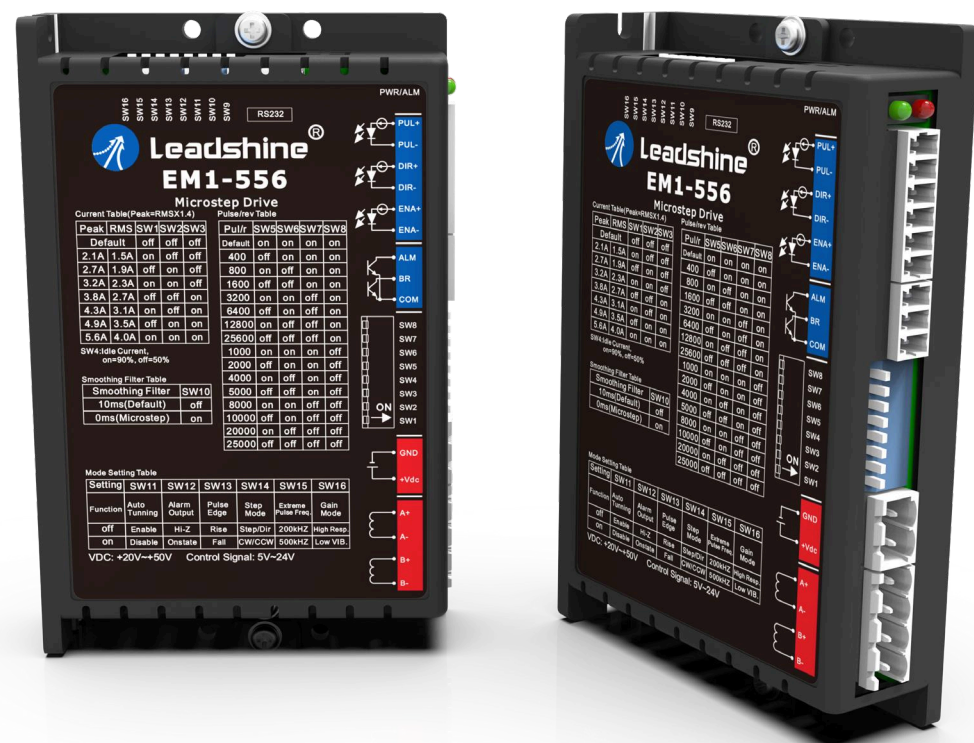

EM1 Series

New Generation Digital Stepper Drive

EM1 series is a new general-purpose pulse stepper driver launched by Ledshine company, which adopts the latest open-loop stepper drive control algorithm and integrates more than 20 years of stepper drive application experience. Outstanding performance

The new EM1 digital series is based on the classic DM series, not only the function has been optimized, the performance has been improved, and the cost has been slightly reduced. The whole series has a debugging port, second sets of functional DIPs and metal heat sinks ensure superior functionality and performance while achieving ultimate stability and reliability.

Overview

Compatible with 5-24 V pulse input

- Opto-coupling isolation supports differential signal input, compatible with 5-24V pulse signal. No resistor required when using 24V input.

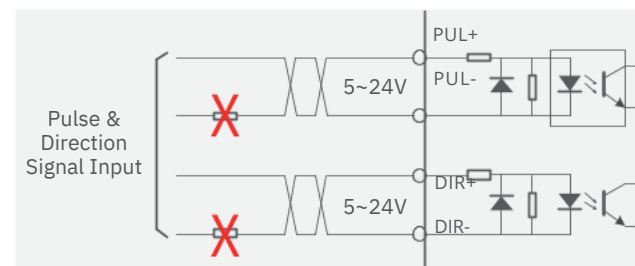

2nd DIP switches

- Can be used to set filter time, double pulse mode, limit pulse frequency 500 kHz (default 200 kHz), etc.

| Dip Switch | Function | Description |
|------------|---------------------------------|---------------------------------------|
| SW 9 | Microfine / filter setting | No filtering / filtering |
| SW10 | auto-tuning setting | Power-on auto-tuning / no auto-tuning |
| SW11 | Alarm output | Often open / often closed |
| SW12 | Effective edge settings | Rising edge / falling edge |
| SW13 | Pulse mode setting | Single-pulse / double-pulse |
| SW14 | Limit pulse frequency selection | 500kHz / 200kHz |

Support both pulse and IO control

- Can be switched using tuning software to meet the operation requirements of more scenarios.

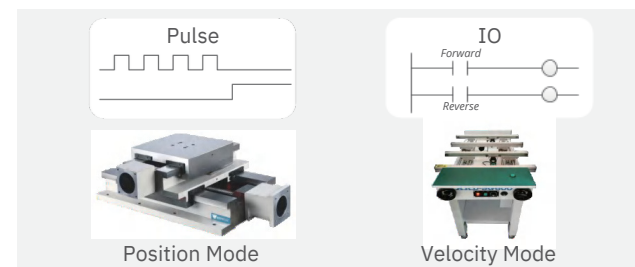

Built-in microscale

- Built-in microcopy power ridge for smooth motion curves.

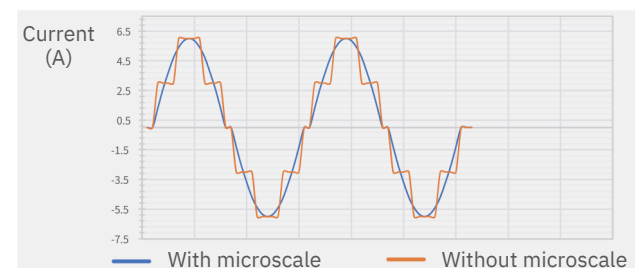

High Response & Low Vibration

- High Response Mode and Low Vibration Mode can be set using 2nd dip switch. Integrated with anti-resonance algorithm, motor jitter can be prevented when running at low speed.

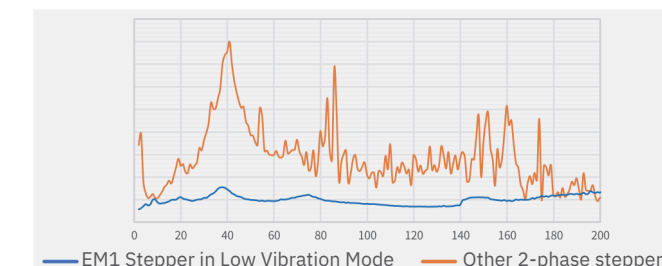

With alarm and brake output

- With alarm and brake output function, suitable for a variety of applications.

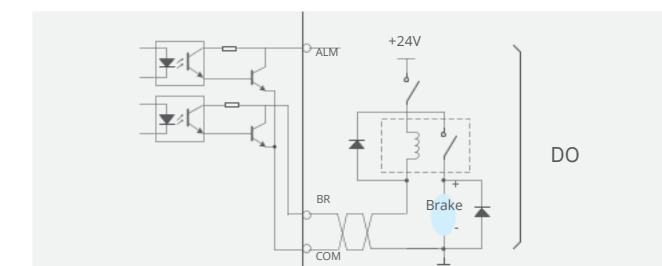

S-Curve



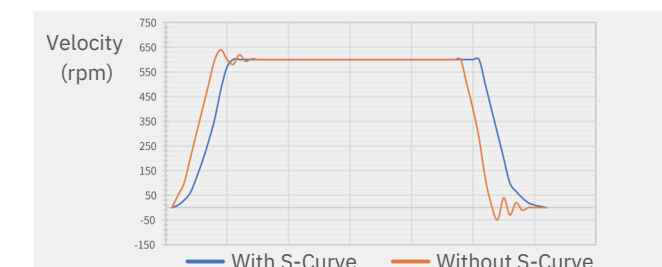



- Integrated S-Curve acceleration and deceleration Smooth speed curve, motor starts and stops at more stable pace.

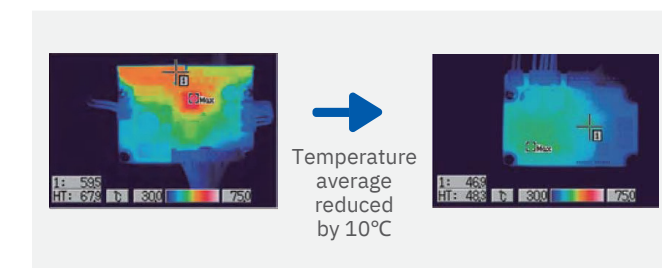

Lower motor running temperature

- High-precision current control, suppress electromagnetic noise, lowering motor temperature.



| Drive Model |  |  |  |  |  |  |
|---------------------------------------|---|---|---|--|---|---|
| | EM1-422 | EM1-432 | EM1-542 | EM1-556 | EM1-870 | EM1-882AC |
| Dimension (L*W*H) | 86*55.5*20.5 | | 118*75.5*25.5 | 118*75.5*34 | | 151*97*52 |
| Matching Motors (Frame Size) | 20/28/35/42 | 35/42 | 57 | 57/60 | 60/86 | 86 |
| Input Voltage | 20~36Vdc | 20~36Vdc | 24~50Vdc | 24~50Vdc | 24~80Vdc | 20~70Vac 30~100Vdc |
| Max. Continuous Current Output | 2.2A | 3.2A | 4.2A | 5.6A | 7.0A | 8.2A |
| Pulse Voltage Input | 5~24Vdc | | | | | |
| Max. Pulse Frequency | 200kHz, 500kHz Configurable | | | | | |
| Max. Current Output (Signal) | 100mA (30Vdc Max. Voltage) | | | | | |

Dimensions

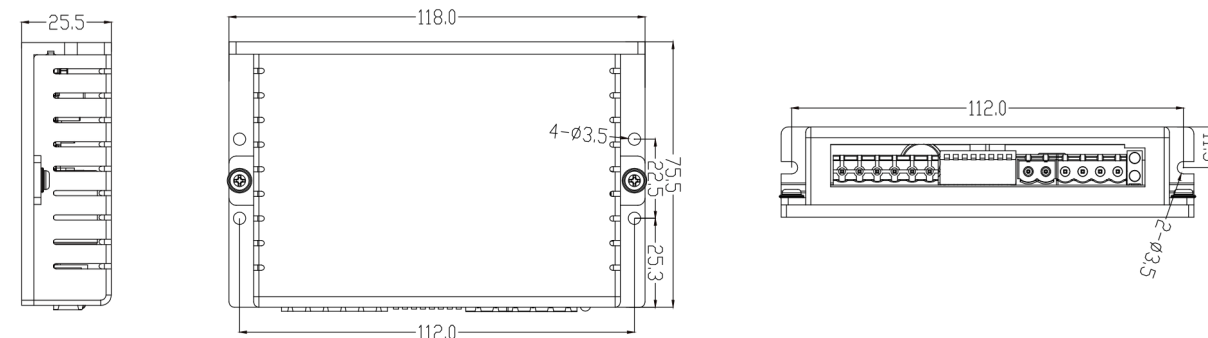

DIP Switch 2

| Switch | Settings |
|--------|-----------------------|
| SW9 | Microminiature/Filter |
| SW10 | |
| SW11 | Auto Tuning |
| SW12 | Alarm Output |
| SW13 | Signal Edge |
| SW14 | Pulse Mode |
| SW15 | Pulse Frequency Limit |
| SW16 | Gain Switching |

RS232 Port

| Pin | Signal | Label |
|-----|--------|---------------------------------|
| 1 | TxD | RS232 Transmit |
| 2 | GND | Ground |
| 3 | RxD | RS232 Receive |
| 4 | +5V | 5V Power Supply Positive (50mA) |

LED Indicator

| Light | Signal |
|-------|--------------|
| Green | Power ON PWR |
| Red | Alarm ALM |

Input

| Pin | Function |
|------|-----------|
| PUL+ | Pulse |
| PUL- | |
| DIR+ | Direction |
| DIR- | |
| ENA+ | Enable |
| ENA- | |

DIP Switch 1

| Switch | Settings | Switch Settings | |
|--------|-------------------|-----------------|-----------|
| SW1 | Dynamic Current | SW5 | Precision |
| SW2 | Direction | SW6 | |
| SW3 | Half/Full Current | SW7 | |
| SW4 | | SW8 | |

Output

| Pin | Function |
|-----|---------------|
| ALM | Alarm Signal |
| BR | Brake Signal |
| COM | Signal Common |

Power Port

| Pin | Function |
|-----|------------------|
| GND | Power input port |
| Vdc | |

Input

| Pin | Function |
|-----|---------------|
| A+ | Motor Phase-A |
| A- | |
| B+ | Motor Phase-B |
| B- | |

Drive Wiring Diagram

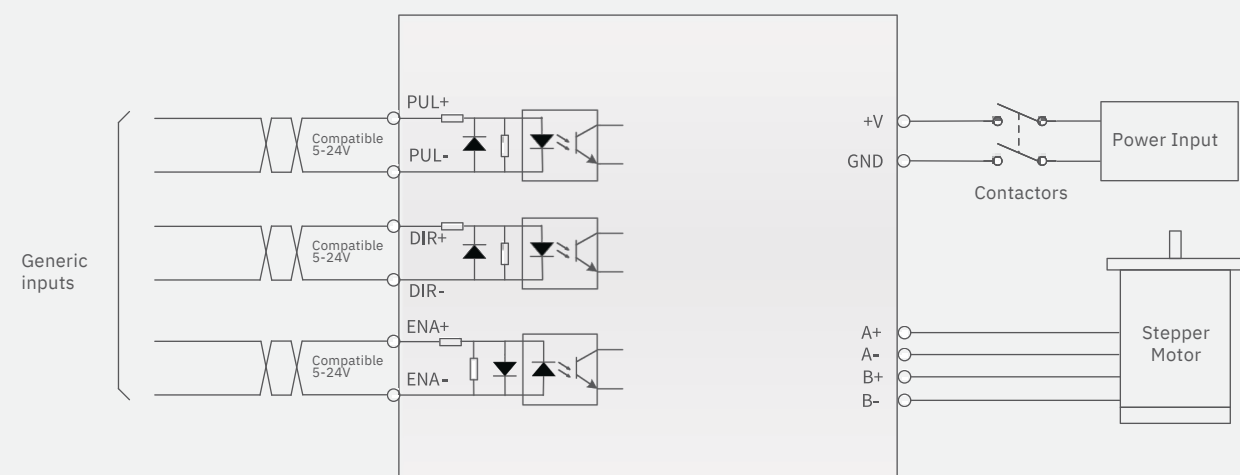

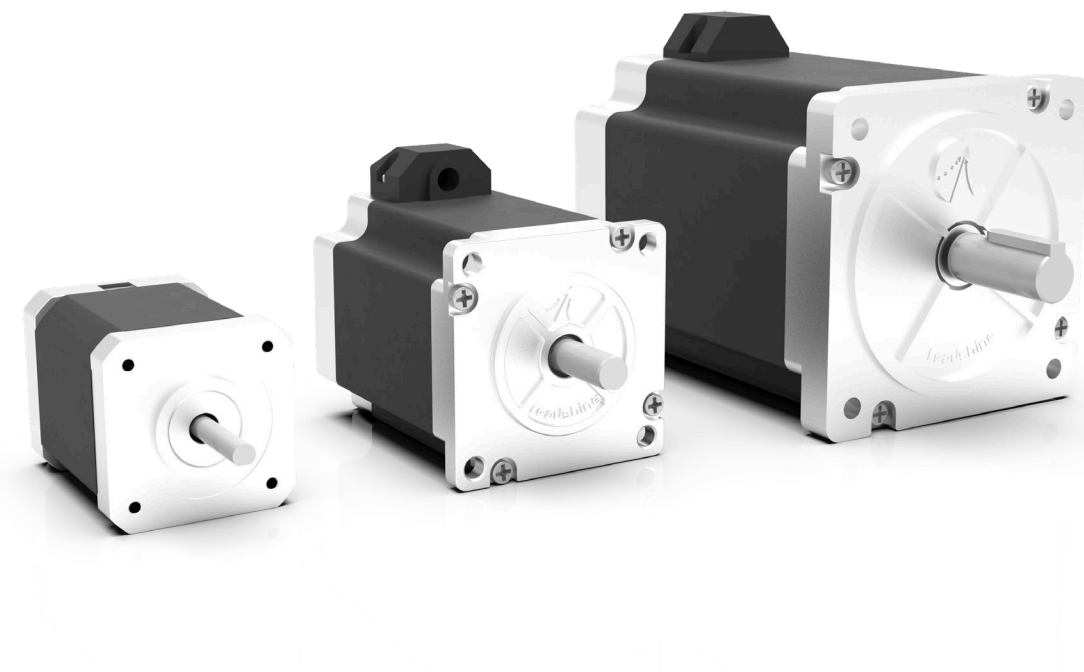

Stepper Motors

CM Series

- Replace HS series stepper motors
- Frame size of NEMA8 to 42
- High reliability, Low motor heating, noise and vibration
- Multiple phase current optional for the same motor

Introduction

By implementing latest design and advanced manufacturing technologies, Leadshine offers hybrid stepper motors in wide frame sizes 8, 11, 14, 16, 17, 23, 24, 34, and 42. Those stepper motors are made of premium quality materials. Compared with ordinary stepper motors on the market. Those stepper motors outperforms in many aspects such as higher torque in all speed ranges, higher precision, lower heating, and lower vibration. Due to the implementation of highly automated manufacturing process and rigid quality assurance control, Leadshine CM series stepper motors are highly reliable with high product consistency.

High Torque:
Latest design for compact size but high torque.

Low Heating:
Use of high quality silicon steel to ensure low motor heating.

Smooth Motion:
Core components from global leading suppliers.

High Consistency:
Highly automated manufacturing process and rigid quality control.

Leadshine CM series stepper motors are available in the following options:

- Standard single shaft stepper motors.
- Stepper motors with planetary gearboxes.
- IP 65 waterproof stepper motors.
- Stepper motors with encoder, brake, gearboxes.
- Dual shaft stepper motors.
- Stepper motors with encoders (also called closed loop stepper motors).
- Stepper motors with electromagnetic brakes.

Leadshine CM stepper motors have been widely implemented in many industrial applications such as CNC routers, laser cutters, plasmas, plotters, medical equipment, Battery manufacturing product lines, textile machines, packaging machines, etc.

Stepper Motor with brake

=

CM Series Stepper Motor

+

Permanent magnet brake

Low noise

Quick response

Low heat

CM series waterproof stepper motor, compared with the standard type, the back cover is redesigned, the lead wire is changed to waterproof connector, new sealing material is added between the front & back cover and the body, the motor body is made a comprehensive waterproof treatment, the motor shaft is selected high quality oil seal, so that the motor IP rate is IP65. can be applied to all kinds of wet, water, outdoor, oil splashing occasions.



DM Series -- AC Power Input

| | |
|-----------------------|---|
| Step Angle | 1.8° |
| Position Accuracy | ±0.09° |
| Temp Rise(Max.) | Max. 85K |
| Operation Environment | Temperature: -10°C - +50°C; Humidity: Max. 85% |
| Insulation Class | B |
| Insulation Resistance | Min. 100 MΩ, 500 V DC |
| Dielectric Strength | 500 VAC, 1 min |
| Radial Play | 0.025 mm Max. (Load 5N) |
| Axial Play | 0.075 mm Max. (Load 10N) |

Installation & Operation Conditions

| Motor Size | NEMA17 | NEMA23 | NEMA24 | NEMA34 |
|---|--|--------|--------|--------|
| Store Temperature | -10°C ~ +50°C | | | |
| Store Humidity | Max. 85% | | | |
| Operation Environment | Non-corrosive gas and dust; No direct contact with water, oil (except the waterproof type) | | | |
| Radial Load(N) (Distance to the flange 10mm) | 30 | 75 | 90 | 300 |
| Axial Load(N) | Less than motor weight | | | |

NEMA 11 (28mm)

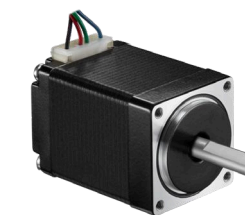

| Models | Length (mm) | Holding Torque (N.m) | Rate Current (A) | Resistance/Phase (Ω) | Inductance/Phase (mH) | Inertia (kgm ² *10 ⁻⁴) | Matched Drives |
|---------|-------------|----------------------|------------------|----------------------|-----------------------|---|----------------|
| 28CM006 | 32 | 0.06 | 1.2 | 1.4 | 1.0 | 0.00 | EM415S |
| 28CM010 | 41 | 0.1 | 1.2 | 1.8 | 1.6 | 9 | EM415S |
| 28CM013 | 51 | 0.13 | 1.2 | 2.2 | 2.3 | 0.01 | EM415S |

3
0.01
8

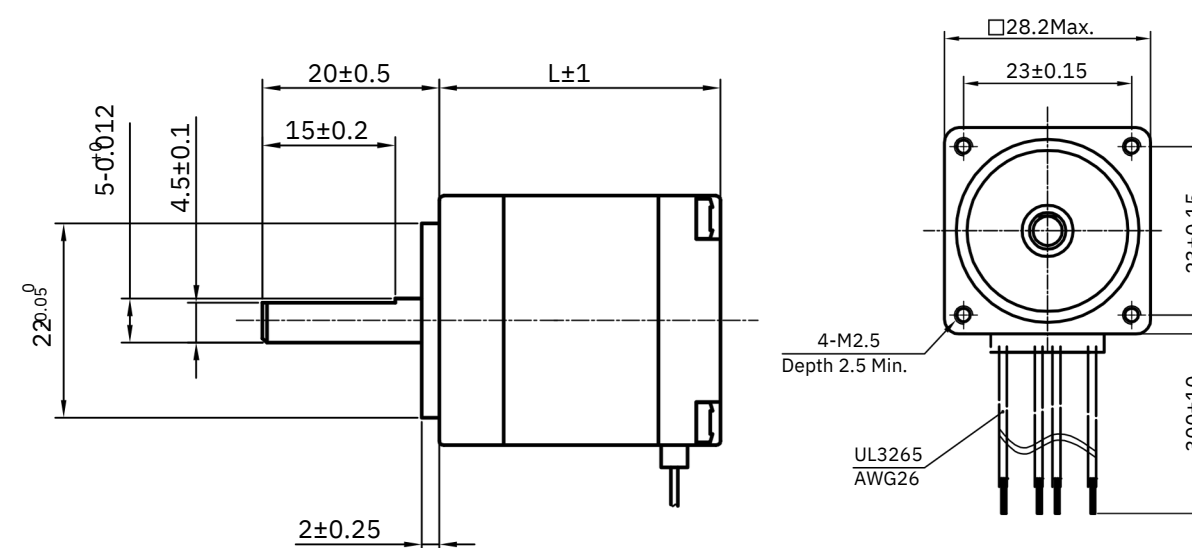

NEMA 8 (20mm)

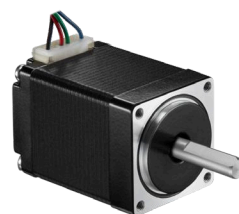

| Models | Length (mm) | Holding Torque (N.m) | Rate Current (A) | Resistance/Phase (Ω) | Inductance/Phase (mH) | Inertia (kgm ² *10 ⁻⁴) | Matched Drives |
|---------|-------------|----------------------|------------------|----------------------|-----------------------|---|----------------|
| 20CM003 | 33 | 0.03 | 0.6 | 5.7 | 2.6 | 0.00 | EM415S |
| 20CM005 | 45 | 0.05 | 0.6 | 7 | 3.4 | 3 | EM415S |

0.00

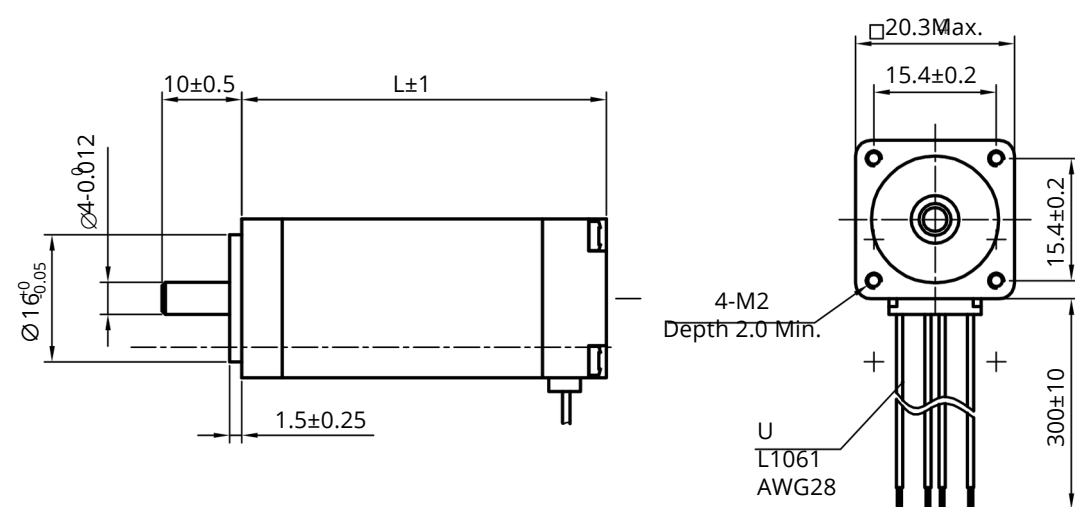

NEMA 14 (35mm)

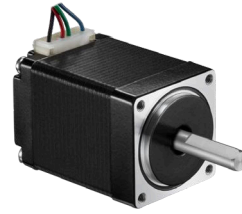

| Models | Length (mm) | Holding Torque (N.m) | Rate Current (A) | Resistance/Phase (Ω) | Inductance/Phase (mH) | Inertia (kgm ² *10 ⁻⁴) | Matched Drives |
|---------|-------------|----------------------|------------------|----------------------|-----------------------|---|----------------|
| 35CM015 | 31 | 0.15 | 2 | 0.8 | 1.3 | 0.01 | EM422S |
| 35CM04 | 47 | 0.36 | 2 | 1.2 | 1.9 | 9 | EM422S |

0.02
6

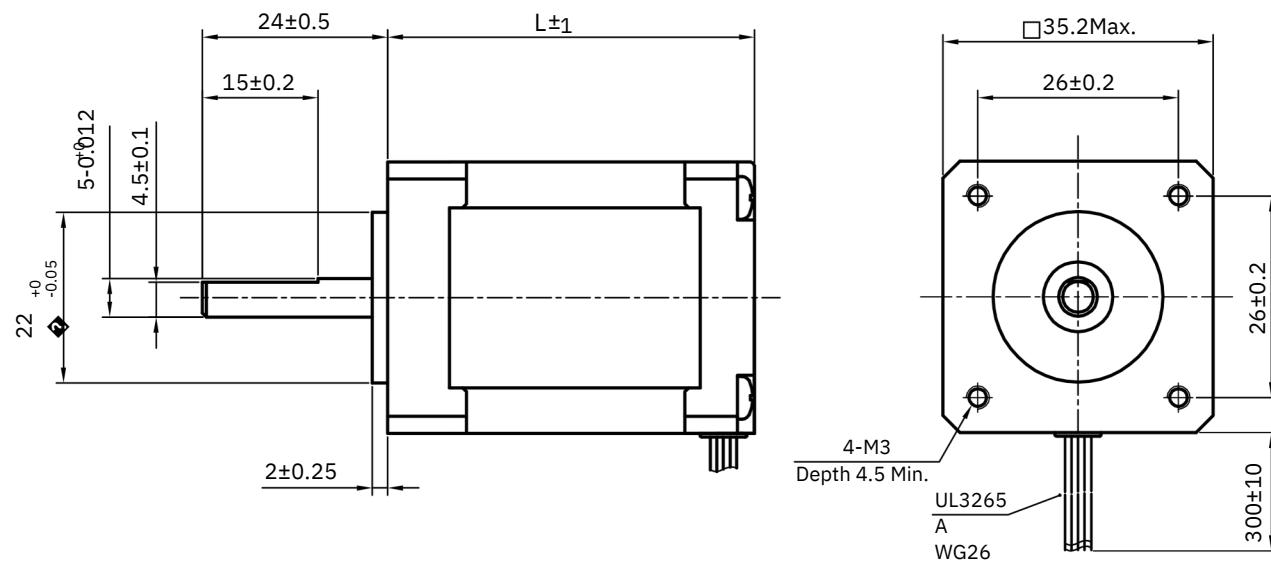

NEMA 17 (42mm)



| Models | Length (mm) | Holding Torque (N.m) | Rate Current (A) | Resistance/Phase (Ω) | Inductance/Phase (mH) | Inertia (kgm ² *10 ⁻⁴) | Matched Drives |
|-----------|-------------|----------------------|------------------|----------------------|-----------------------|---|----------------|
| 42CM02-1A | 33 | 0.21 | 1 | 4.5 | 6.5 | 0.03 | EM415S |
| 42CM02 | | 0.21 | 1.5 | 1.4 | 1.4 | 5 | EM422S |
| 42CM04-1A | 40 | 0.4 | 1 | 4.0 | 7.9 | 0.03 | EM415S |
| 42CM04 | | 0.4 | 1.5 | 2.3 | 4.3 | 5 | EM422S |
| 42CM06-1A | 47 | 0.6 | 1.5 | 2.2 | 4.5 | 0.05 | EM422S |
| 42CM06 | | 0.6 | 2.5 | 0.9 | 1.6 | 4 | EM532MINI |
| 42CM08-1A | 60 | 0.8 | 1.5 | 3.0 | 6.9 | 0.05 | EM422S |
| 42CM08 | | 0.8 | 2.5 | 1.0 | 2.4 | 4 | EM532MINI |

0.07
2

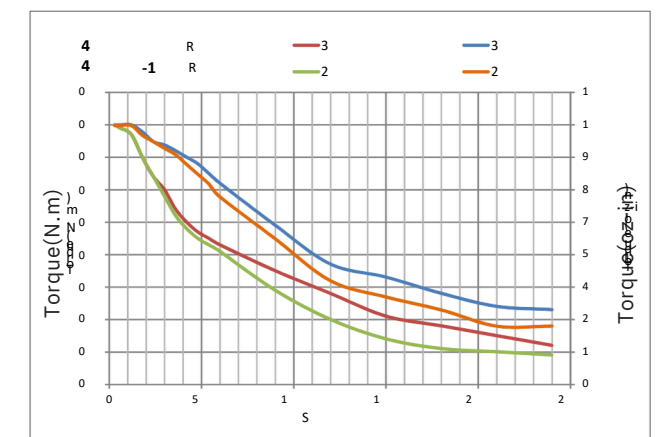
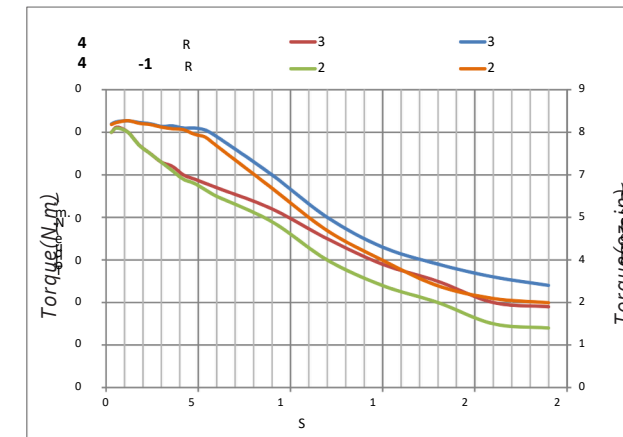
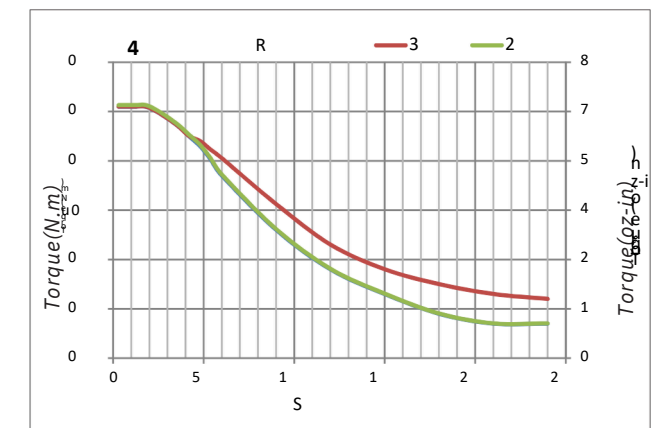
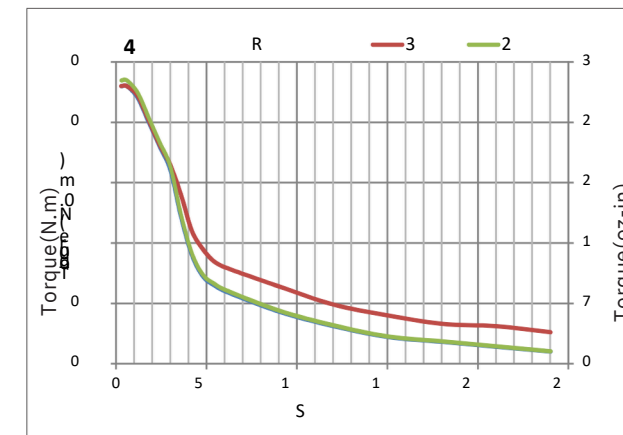
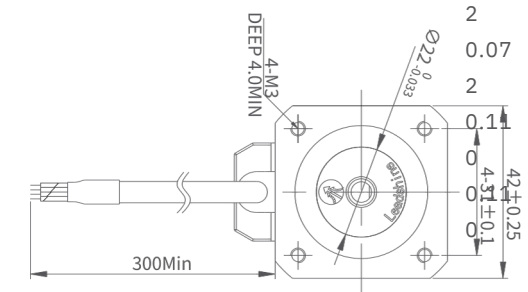
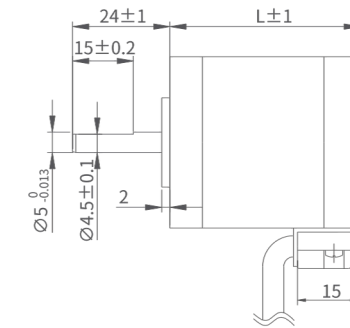

NEMA 23 (57mm)



| Models | Length (mm) | Holding Torque (N.m) | Rate Current (A) | Resistance/Phase (Ω) | Inductance/Phase (mH) | Detent Torque (kgm ² *10 ⁻⁴) | Inertia (kgm ² *10 ⁻⁴) | D (mm) | Matched Drives |
|-----------|-------------|----------------------|------------------|----------------------|-----------------------|---|---|--------|----------------|
| 57CM06 | 41 | 0.6 | 3 | 0.7 | 1.4 | 6.35 | 0.12 | | EM542S |
| 57CM13-3A | 55 | 1.3 | 3 | 0.8 | 2.8 | 6.35 | 0.3 | | EM542S |
| 57CM13 | | 1.3 | 4 | 0.42 | 1.6 | 6.35 | | | EM542S/EM556S |
| 57CM12X | | 1.2 | 4 | 0.6 | 1.4 | 6.35 | | | EM542S/EM556S |
| 57CM21X | 76 | 2.1 | 4 | 0.6 | 2.4 | 8 | 0.48 | | EM542S/EM556S |
| 57CM23-3A | | 2.1 | 3 | 1.1 | 4.2 | 8 | | | EM542S/EM556S |
| 57CM23-4A | 76 | 2.3 | 4 | 0.5 | 1.75 | 8 | 0.52 | | EM556S |
| 57CM23 | | 2.3 | 5 | 0.38 | 1.74 | 8 | | | EM556S/EM870S |
| 57CM22X | 85 | 2.2 | 5 | 0.34 | 3.2 | 8 | | | EM542S/EM556S |
| 57CM26-4A | 85 | 2.6 | 4 | 0.8 | 2 | 8 | | | EM556S/EM870S |
| 57CM26 | | 2.6 | 5 | 0.44 | 2 | 8 | | | EM556S/EM870S |

Note: Motors with 1/4 in(6.35mm) shaft diameter are available.

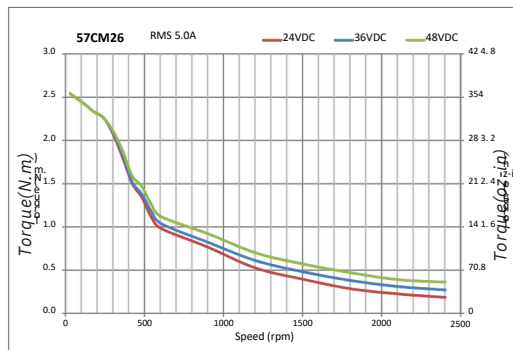
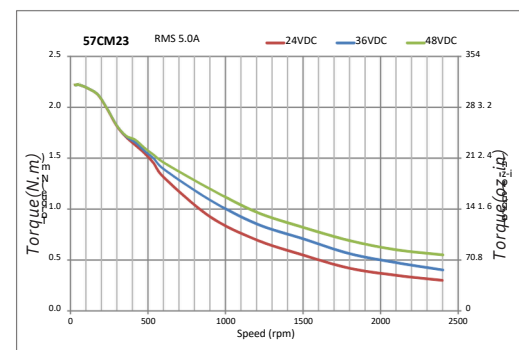
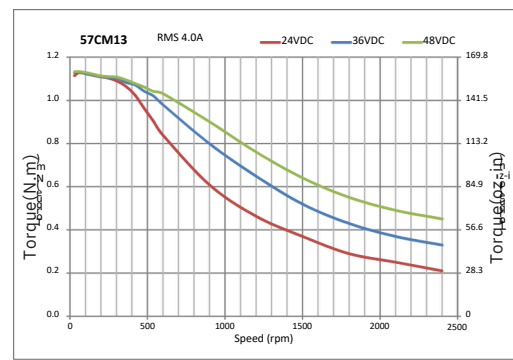
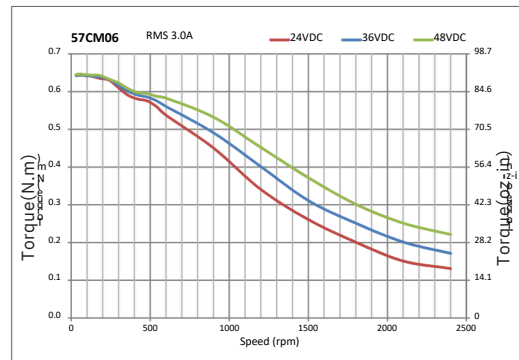
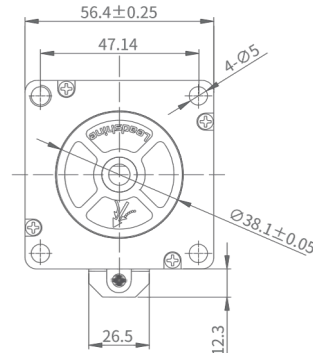
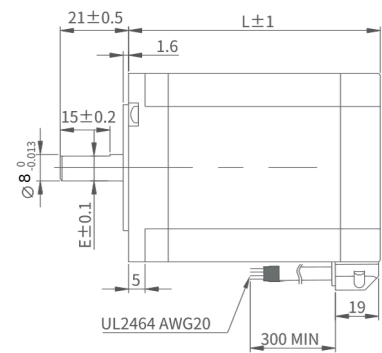

NEMA 23 (57mm)

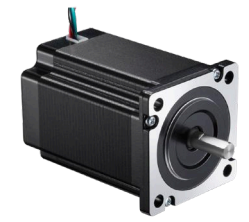
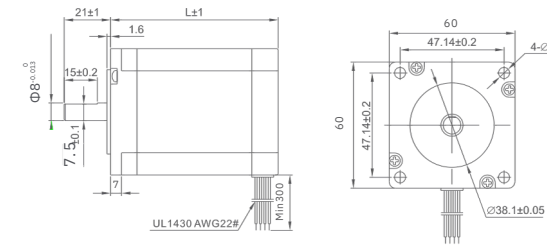

| Models | Length (mm) | Holding Torque (N.m) | Rate Current (A) | Resistance/Phase (Ω) | Inductance/Phase (mH) | Detent Torque (N.m) | Inertia (kgm ² *10 ⁻⁴) | D (mm) | Matched Drives |
|------------|-------------|----------------------|------------------|----------------------|-----------------------|---------------------|---|--------|----------------|
| D57CM21-4A | 67 | 2.1 | 4 | 0.5 | 1.77 | 0.09 | 0.57 | 7.5 | EM556S |
| D57CM21 | | 2.1 | 5 | 0.21 | 0.75 | | | | EM556S/EM870S |
| D57CM31-4A | 88 | 3.1 | 4 | 0.62 | 2.8 | 0.10 | 0.84 | 7.5 | EM556S |
| D57CM31 | | 3.1 | 5 | 0.26 | 1.18 | | | | EM556S/EM870S |

NEMA 24 (60mm)

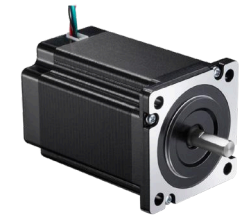

| Models | Length (mm) | Holding Torque (N.m) | Rate Current (A) | Resistance/Phase (Ω) | Inductance/Phase (mH) | Detent Torque (N.m) | Inertia (kgm ² *10 ⁻⁴) | D (mm) | Matched Drives |
|---------|-------------|----------------------|------------------|----------------------|-----------------------|---------------------|---|--------|----------------|
| 60CM22X | 67 | 2.2 | 5 | 0.33 | 1.05 | 0.07 | 0.4 | 8 | EM556S/EM870S |
| 60CM30X | 85 | 3.0 | 5 | 0.46 | 2.0 | 0.08 | 9 | 8 | EM556S/EM870S |

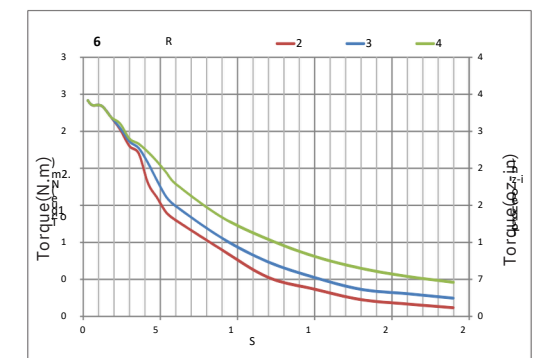
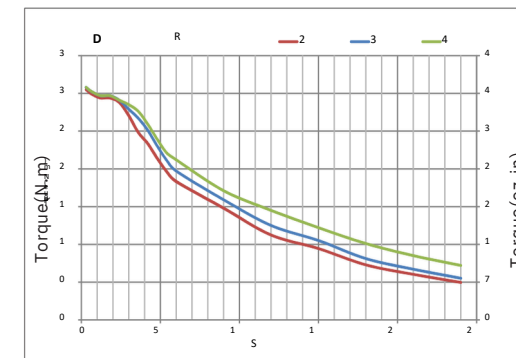
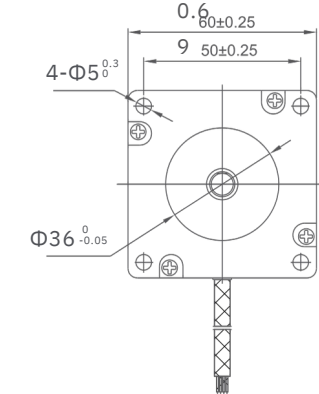
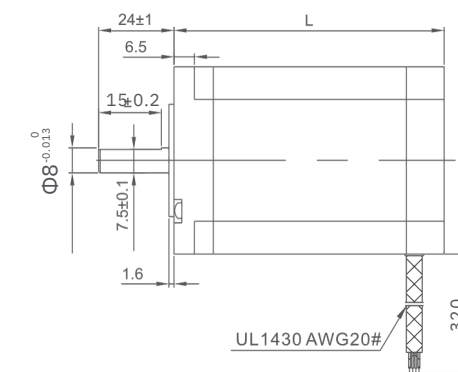

NEMA 34 (86mm)



| Models | Length (mm) | Holding Torque (N.m) | Rate Current (A) | Resistance/Phase (Ω) | Inductance/Phase (mH) | Inertia (kgm ² *10 ⁻⁴) | D (mm) | Matched Drives |
|---------|-------------|----------------------|------------------|----------------------|-----------------------|---|--------|----------------|
| 86CM35 | 65 | 3.5 | 4 | 0.42 | 1.00 | 1.00 | 12.7 | EM556S/EM870S |
| 86CM45 | 80 | 4.5 | 6 | 0.43 | 2.95 | 1.40 | 12.7 | EM882S |
| 86CM80 | 98 | 8.0 | 6 | 0.63 | 4.0 | 2.50 | 12.7 | EM882S |
| 86CM85 | 118 | 8.5 | 6 | 0.53 | 4.25 | 2.70 | 12.7 | EM882S |
| 86CM120 | 129 | 12.0 | 6 | 0.75 | 5.30 | 2.94 | 14 | EM882S/DMA882S |

Note: Motors with 1/4 in(6.35mm) shaft diameter are available.

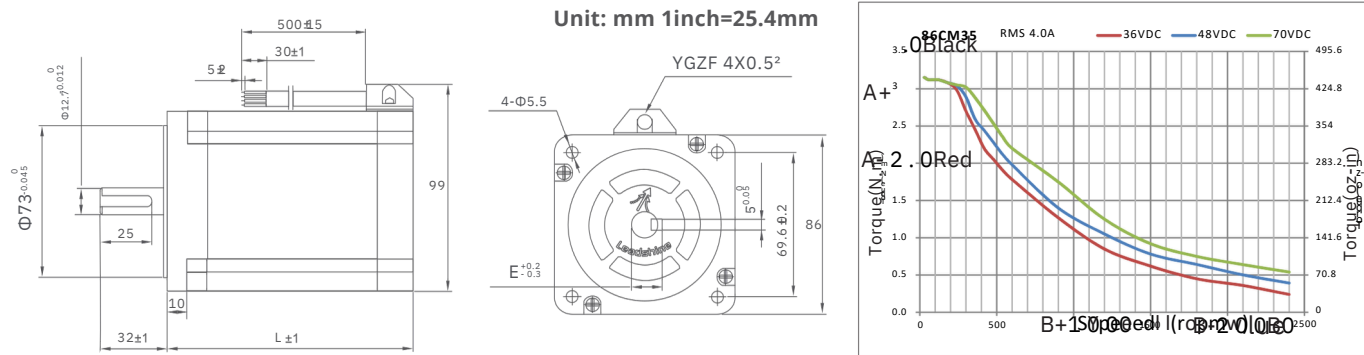

NEMA 42 & 51 (110mm & 130mm)



| Models | Length (mm) | Holding Torque (N.m) | Rate Current (A) | Resistance/Phase (Ω) | Inductance/Phase (mH) | Inertia (kgm ² *10 ⁻⁴) | D (mm) | Matched Drives |
|---------|-------------|----------------------|------------------|----------------------|-----------------------|---|--------|----------------|
| 110CM12 | 115 | 12 | 6 | 0.53 | 6.5 | 7.2 | 19 | DM2282 |
| 110CM20 | 150 | 20 | 6 | 0.8 | 15 | 10.9 | 19 | DM2282 |
| 110CM28 | 201 | 28 | 6.5 | 1.2 | 22 | 16.2 | 19 | DM2282 |
| 130HS27 | 227 | 27 | 6 | 0.86 | 12.5 | 15.7 | 19 | DM2282 |
| 130HS45 | 283 | 45 | 7 | 0.66 | 9.0 | 22.9 | 19 | DM2282 |

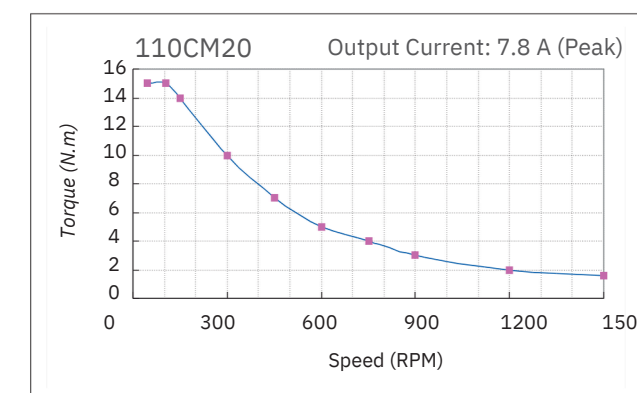
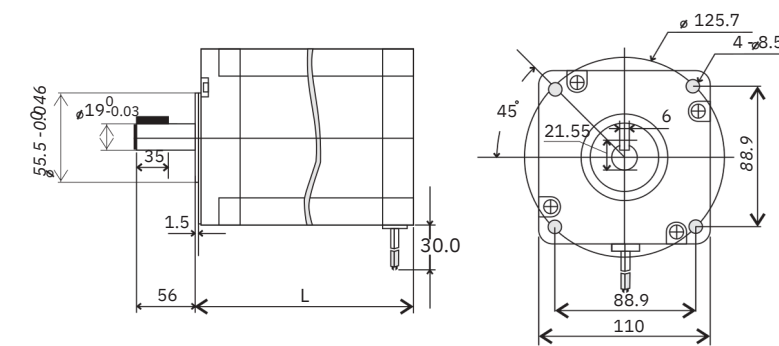
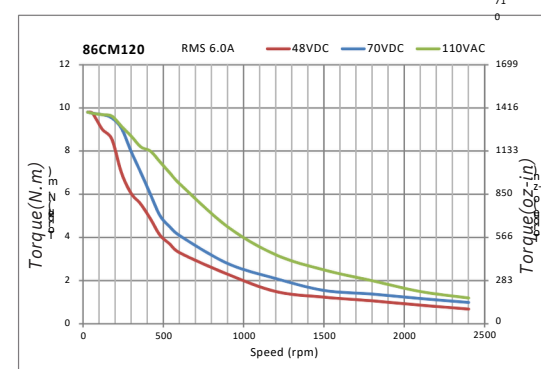
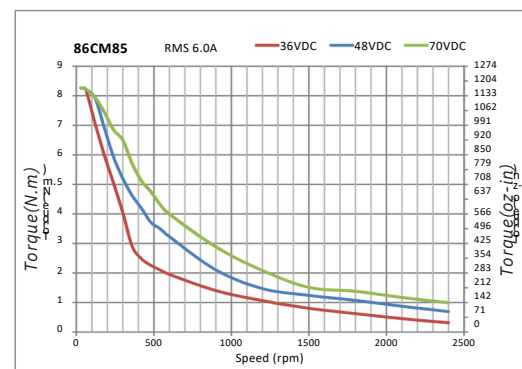
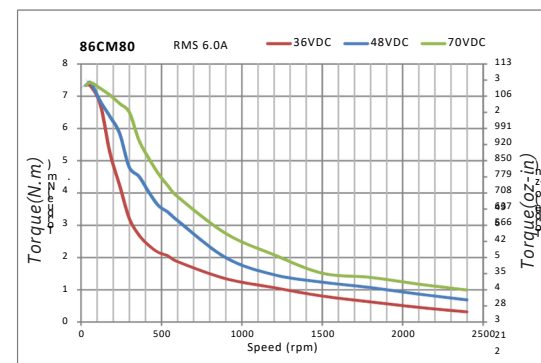
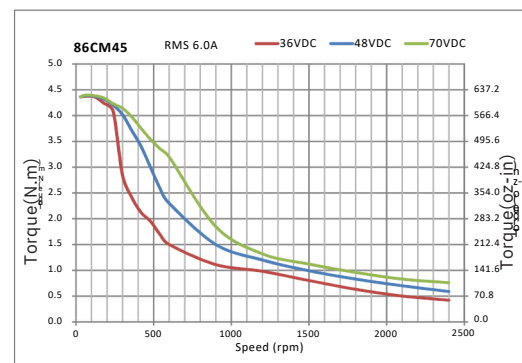
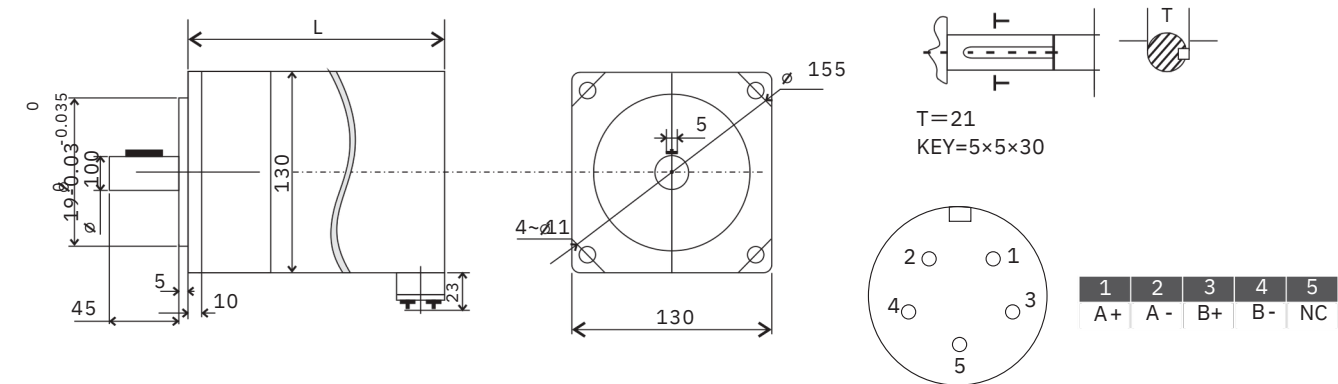

3-phase:NEMA 23, 34, 42



| Models | Length (mm) | Holding Torque (N.m) | Rate Current (A) | Resistance/Phase (Ω) | Inductance/Phase (mH) | Inertia (kgm ² *10 ⁻⁴) | D (mm) | Matched Drives |
|---------|-------------|----------------------|------------------|----------------------|-----------------------|---|--------|----------------|
| 573S09 | 50 | 0.9 | 3.5 | 0.77 | 1.8 | 1.0 | 6.35 | 3DM580S |
| 573S15 | 76 | 1.3 | 5.8 | 0.86 | 2.0 | 0 | 8 | 3DM580S |
| 863S22 | 71 | 2.3 | 5 | 0.9 | 2.8 | 1.4 | 12 | 3ND883 |
| 863S42 | 103 | 4.3 | 5 | 1.35 | 4.5 | 0 | 12 | 3ND883 |
| 863S68H | 135 | 6.8 | 2.3 | 4.5 | 20 | 2.5 | 14 | 3DM2283 |

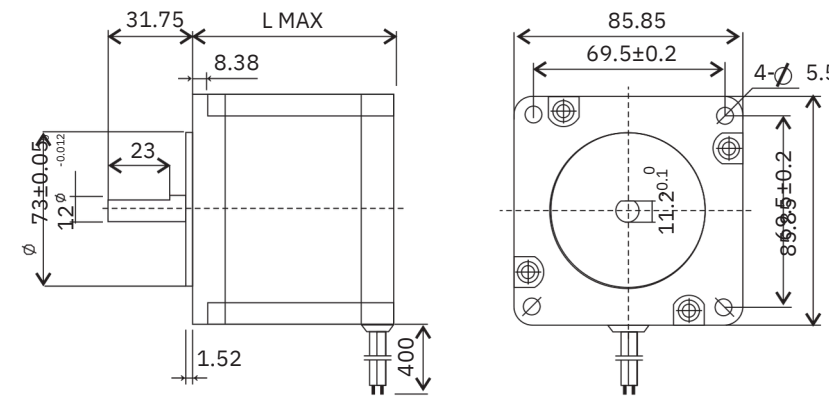

Unit: mm 1inch=25.4mm

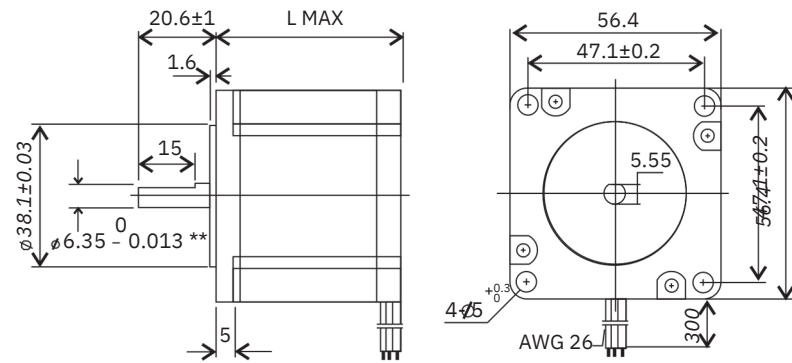
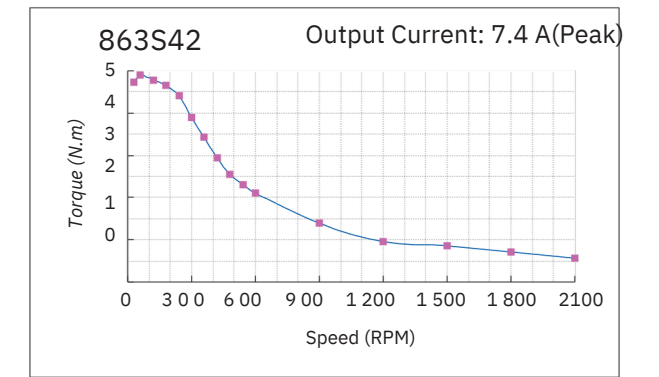
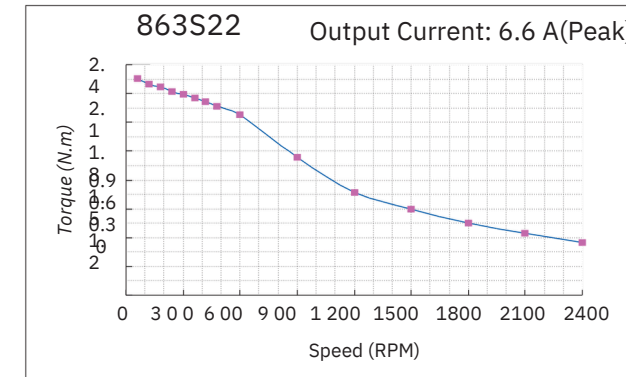
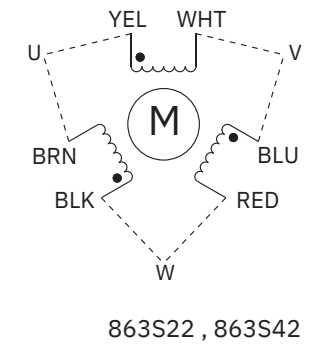

Unit: mm 1inch=25.4mm

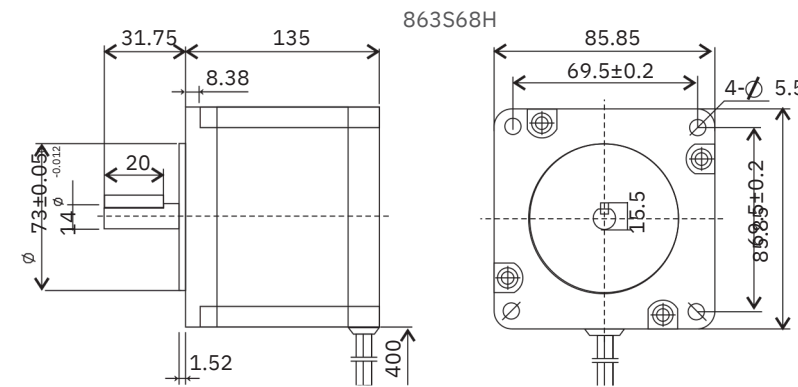
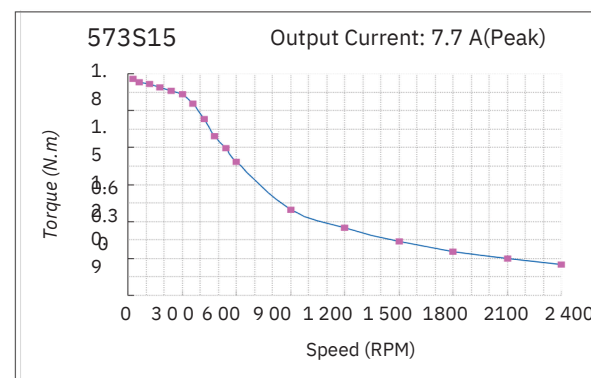
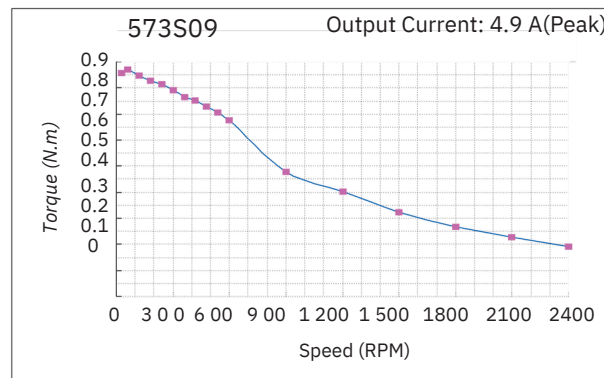
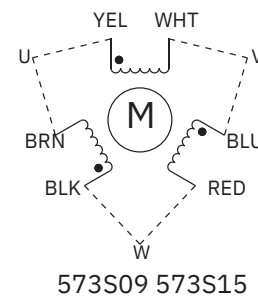

Unit: mm 1inch=25.4mm

| Specifications of Motor Shafts | | |
|--------------------------------|------|-----------|
| Model | T | KEY D |
| 863S68H | 15.5 | 4*4*20 14 |

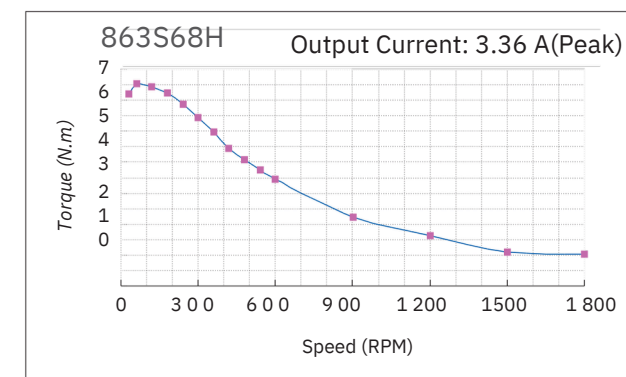
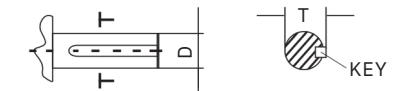



DM5 Series

5-phase Stepper Drive

DM5 series is a new high-end five-phase stepper driver launched by Leadshine, DM5 series includes pulse type and EtherCAT bus type, which has a series of advantages such as higher precision, faster response, lower vibration, smaller size, simple and easier operation, more diverse installation methods, more powerful functions, and more intelligent network.

DM5 series is suitable for import substitution occasions of various high-end equipment, and can be widely used in semiconductor, medical, precision dispensing, wire cutting, laser, engraving and other industry equipment.

Overview

Higher accuracy than two-phase stepper

The basic step angle of the 5-phase stepper motor is 0.72°, and the stopping accuracy can reach 0.05°, which can achieve higher positioning accuracy compared with the 2-phase stepper motor.

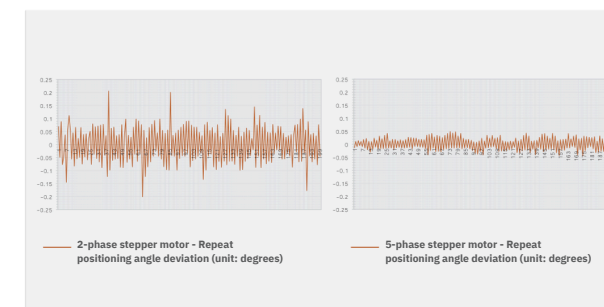

Faster response than AC servo

Compared with AC servo drive, the 5-phase stepper motor has the advantages of more pole pairs, open-loop control, no setting time, faster response speed, and shorter positioning time.

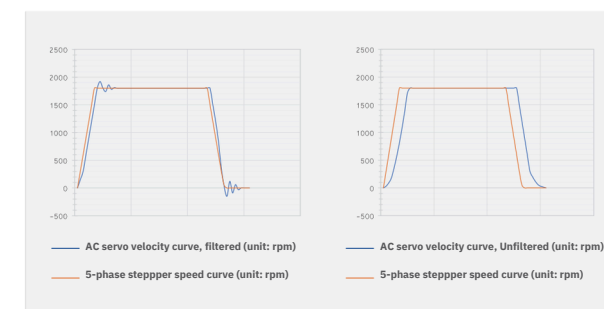

Lower vibration than 2-phase stepping

The basic step angle of the 5-phase stepper motor is 0.72°, which is less fluctuating in speed and less vibration and noise than the 2-phase stepper motor with a basic step angle of 1.8°.

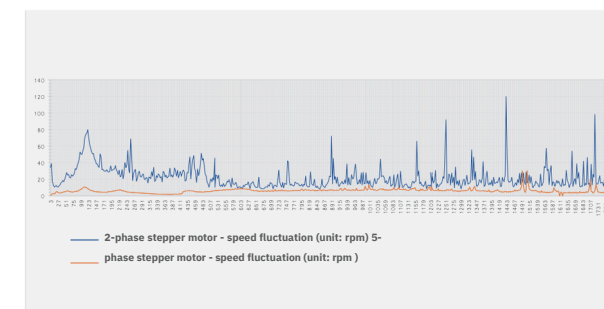

Small size, large energy, Type-C tuning interface, easy to use

small size, huge energy, maximum driving current up to 4A.

Support USB power supply: the driver does not need to be powered on, and the parameters can be modified by plugging in the Type-C data cable;

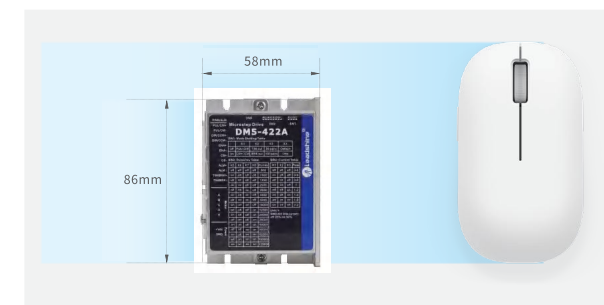

DM5 Series

High-end 5-phase pulse control stepper drives

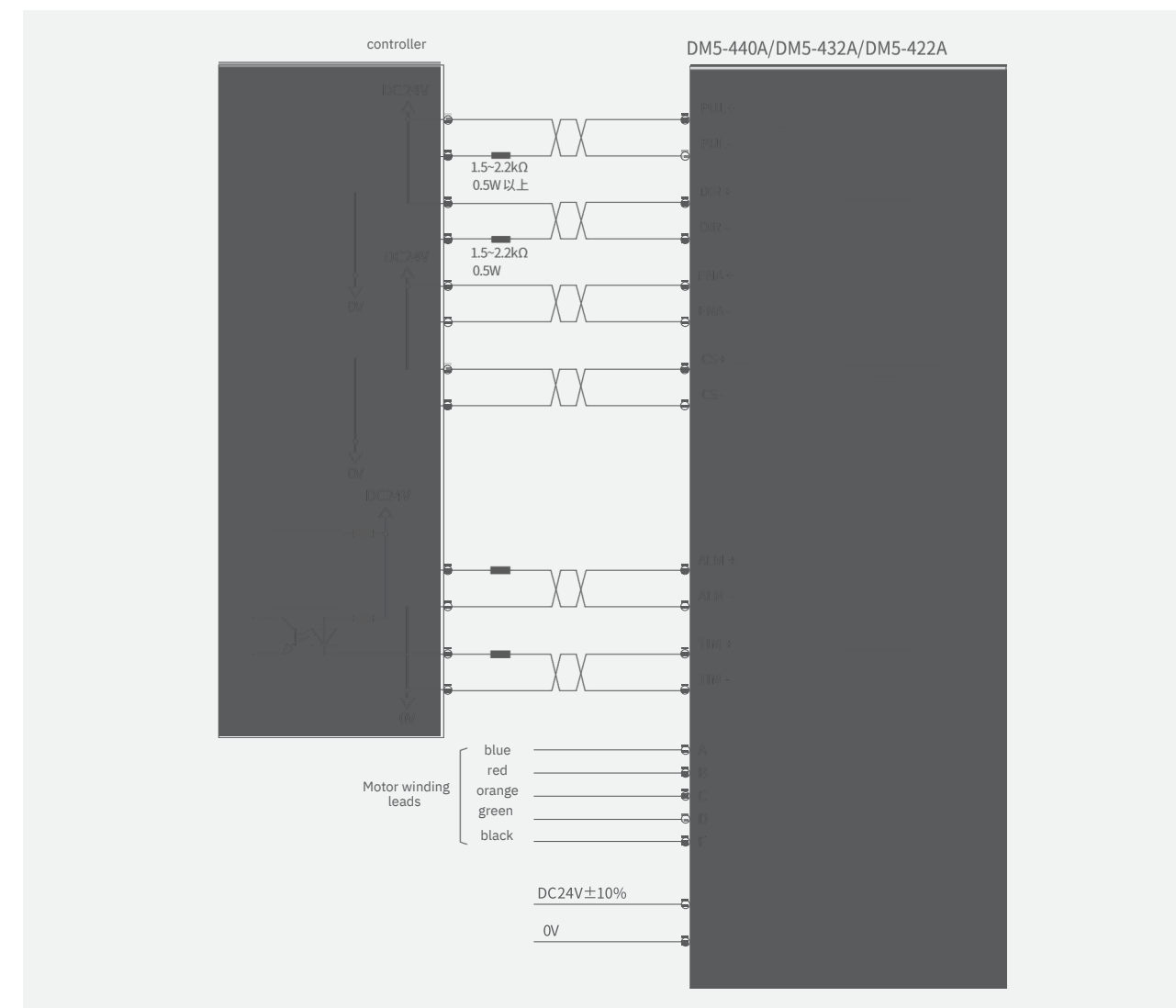
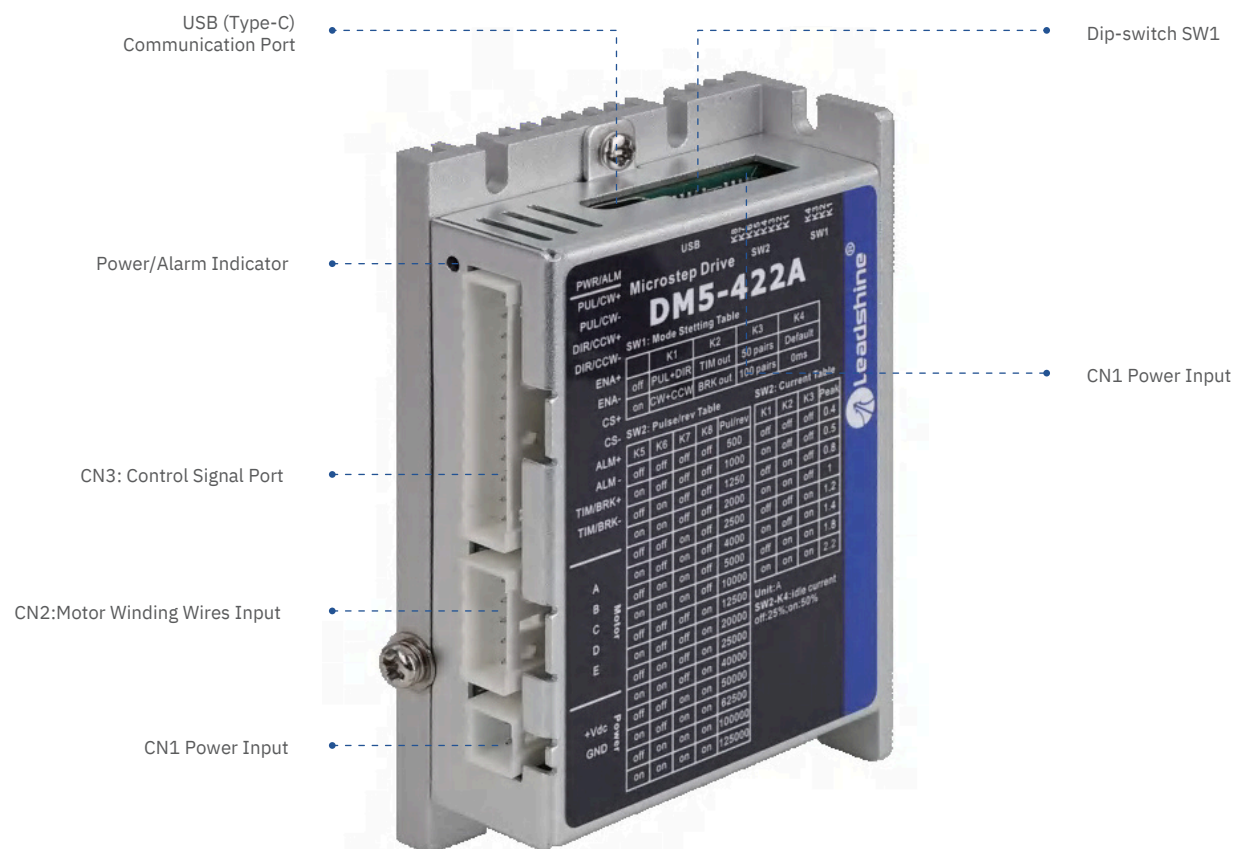

DM5 Series

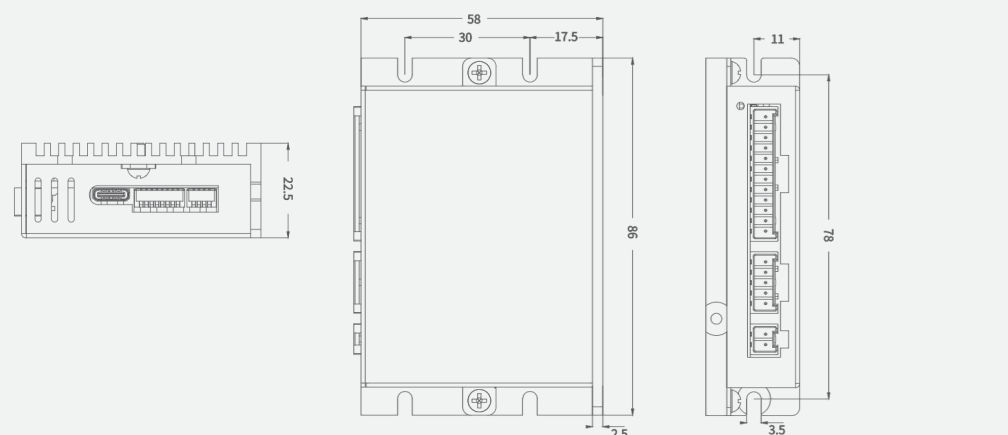

| Drive | DM5-422A | DM5-432A | DM5-440A |
|-------------------------------|-----------------------|----------|----------|
| Matching Motor | Frame 28 | Frame 42 | Frame 60 |
| Power Supply | 24~36Vdc | 24~36Vdc | 24~36Vdc |
| Maximum Output Current (Peak) | 2.2A | 3.2A | 4.0A |
| Pulse Signal Voltage | 5Vdc | | |
| Maximum Pulse Input Frequency | 1MHz | | |
| Input Signal Current | Typical 10Ma (6~16mA) | | |
| Input Signal Voltage | 12V/24V | | |
| Maximum OC Current | 100mA | | |
| Maximum OC Voltage | 30Vdc | | |
| Isolation Resistance | 100 MΩ | | |

DM5-EC series

High-end 5-phase EtherCAT stepper drives

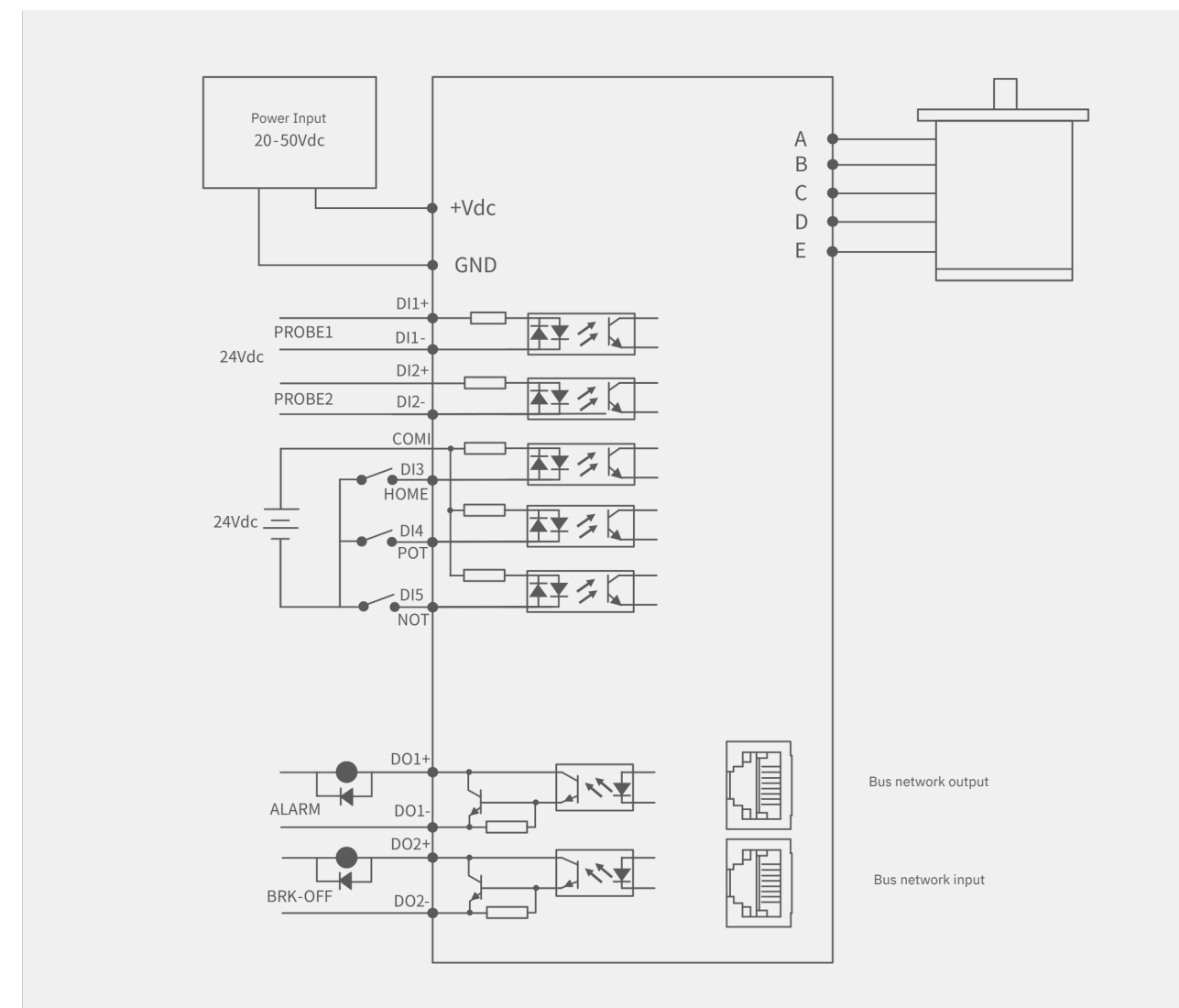
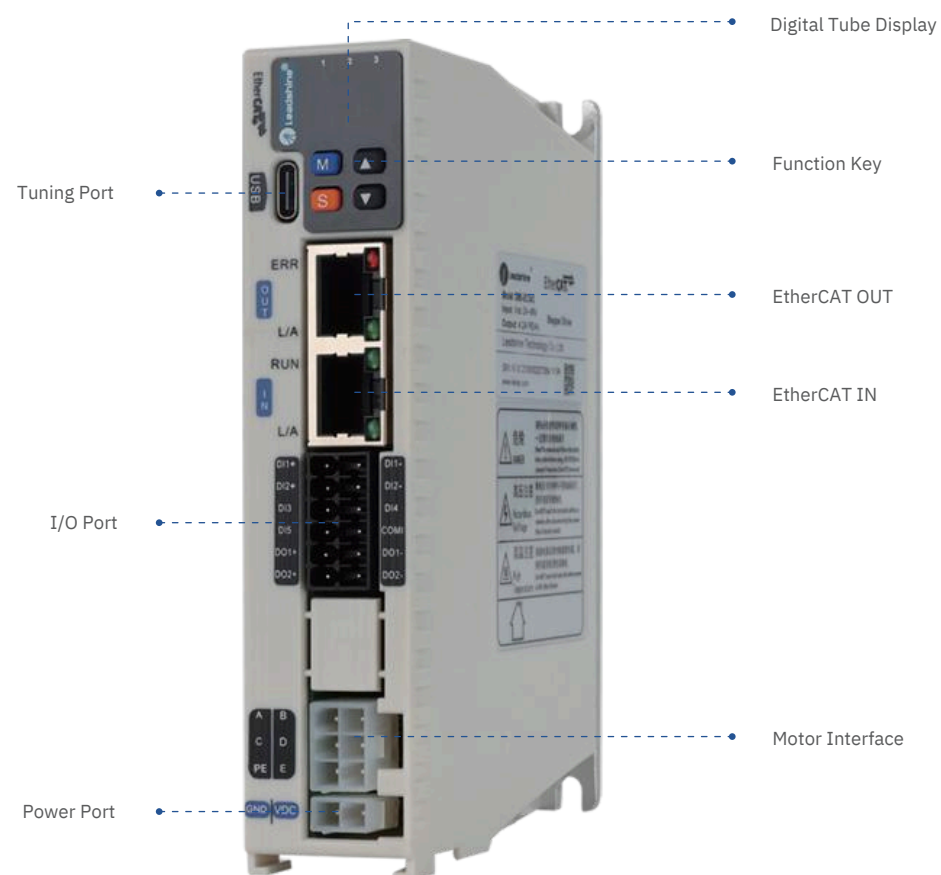

| Drive | DM5-EC522 | DM5-EC532 | DM5-EC542 |
|---|---|-----------|-----------|
| Matching Motor | Frame 28 | Frame 42 | Frame 60 |
| Power Supply | 20~50Vdc | 20~50Vdc | 20~50Vdc |
| Maximum Output Current (Peak) | 2.2A | 3.2A | 4.2A |
| Tuning Port | TYPE-C | | |
| Digital Input | 5 DI | | |
| Input Specification | The control signal is 12~24V, and the function supports probe input, origin, positive limit, negative limit, emergency stop, general input, etc | | |
| Digital Output | 2DO | | |
| Output Specification | OC output, maximum pull-up 30V, maximum output 100mA, function support alarm, brake, general output, etc | | |
| Motor winding interface | 6PIN | 6PIN | 6PI |
| power input | 2PIN | 2PIN | N |
| Communication protocol standards | EtherCAT | | 2PI |
| Control mode | CSP / PP / PV / HM | | N |
| Synchronization mdde | DC Synchronization and Free run mode | | |
| Synchronization period | 0.25~20ms | | |
| Tuning Sostware | Motion Studio | | |
| Isolation Resistance | 100 MΩ | | |

DM5 Series

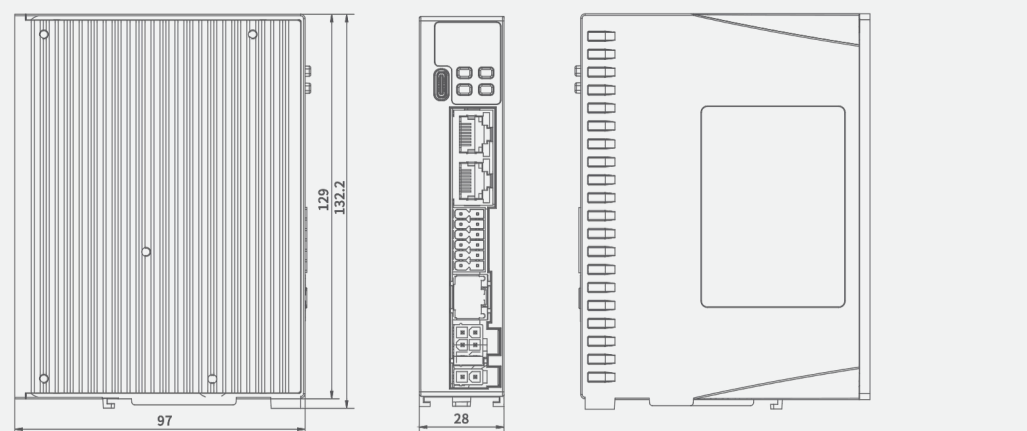

5-phase Stepper Motor

High precision and low noise



NEMA 11 (28MM)



Part Numbers

60
5
CM
11

-

A

| ① Subseries Name | | ④ Motor Type | | ⑧ Standard Custom Code | |
|---|---|---|--|---------------------------|-------------------------------|
| Blank | No special meaning | CM | Cost-effective open-loop stepper motor | S2 | double shaft type |
| D | A product series that is larger than the standard mounting base | | | BZ | brake type |
| ② Frame Number | | ⑤ Motor Torque | | ⑨ Regular Custom Codename | |
| Motor installation size code (e.g. 57 for 57 frame) | | Divide by 10 is the motor holding torque (e.g., 23 means 2.3Nm) | | S | Shaft extension change |
| ③ The Number of Phases of The Motor | | ⑥ Design Code | | L | Leadout changes |
| Blank | Two-phase hybrid stepper motor | | | F | Shaft extension belt platform |
| ⑦ Standard Custom Code | | | | N | optical axis |
| A | Current parameter | | | K | Shaft extension with keyway |
| D | Special application codes | | | I | Shaft diameter change |
| | | | | C | Leadout with connector |
| | | | | M | With synchronous wheels |

| Model | Single / dual-axis | Shaft diameter (mm) | Shaft length (mm) | Length L (mm) | Rear axle diameter (mm) | Rear axle length L1 (mm) |
|-------------|--------------------|---------------------|-------------------|---------------|-------------------------|--------------------------|
| 285CM005 | Single-axis | 5 | 15 | 32.2 | / | / |
| 285CM005-SZ | Dual-axis | 5 | 15 | 33.2 | 5 | 10 |
| 285CM012 | Single-axis | 5 | 15 | 51.8 | / | / |
| 285CM012-SZ | Dual-axis | 5 | 15 | 52.8 | 5 | 10 |
| 863S68H | 135 | 6.8 | 2.3 | 4.5 | 20 | 2.94 |

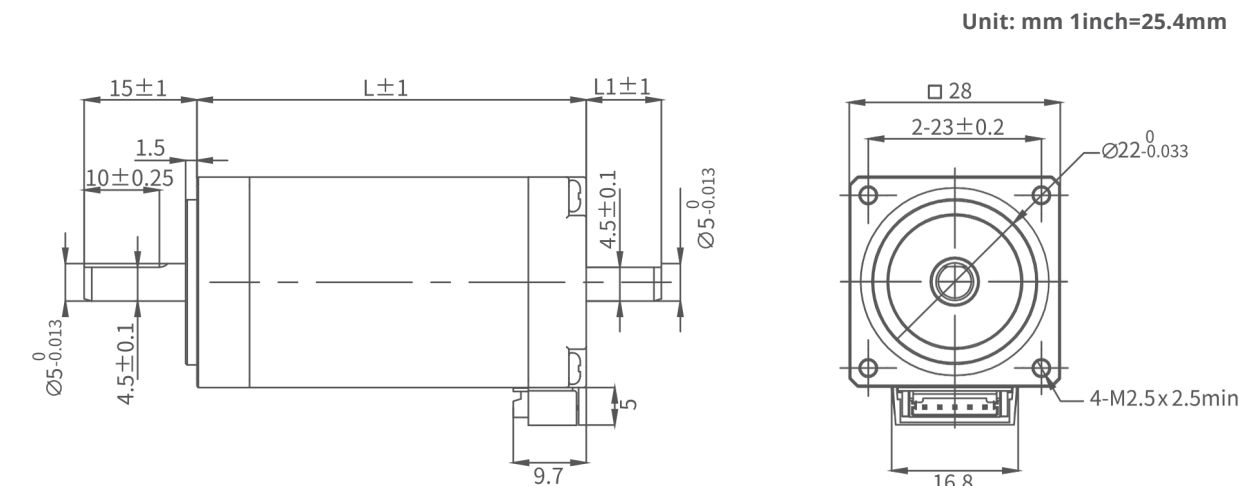

Specifications

| Drive | NEMA 11 | NEMA 17 | NEMA 24 |
|--|--|---------|---------|
| Step angle | 0.72° | | |
| Step angle accuracy | ±0.036° (no load, full step) | | |
| Temperature rise | MAX 80K | | |
| Use environment | Temperature: -10~+50°C; Humidity: 85%MAX | | |
| Insulation rating | B | | |
| Insulation resistance | MIN 100 MΩ, 500VDC | | |
| Withstand voltage | 500VAC, 1 min | | |
| Radial runout | 0.025 mm MAX (load 5N) | | |
| Axial runout | 0.075 mm MAX (load 10N) | | |
| Maximum radial load N (10 mm from flange face) | 15 | 30 | 90 |
| Axial maximum load N | The self-weight of the motor | | |

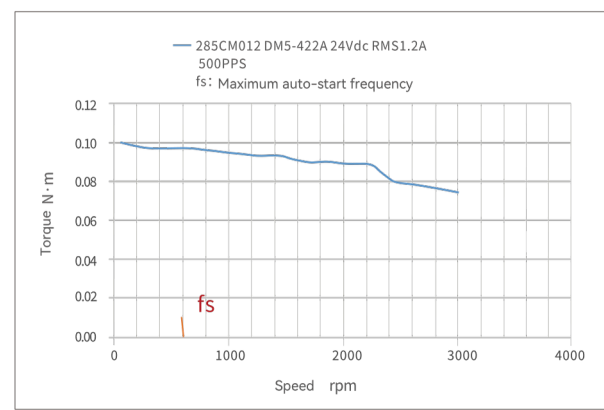
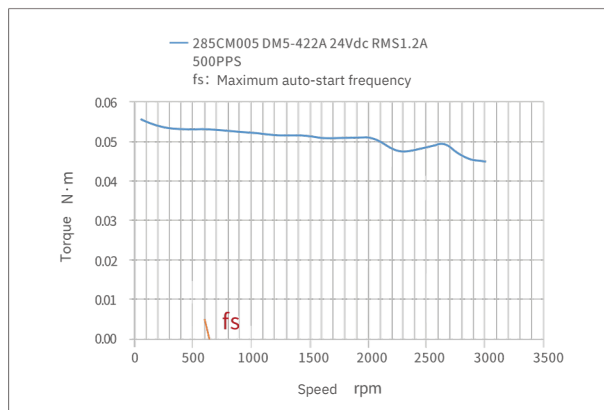

Specifications

| Phase/ Series | Frame size | Length (mm) | Model | Rate Current (A) | Holding Torque (N.m) | Step Angle | Resistance (Ω) | Inertia (kg·cm ²) | Weight (kg) | Matching Drive | Single/ dual-axis |
|---------------|------------|-------------|-------------|------------------|----------------------|------------|----------------|-------------------------------|-------------|----------------|-------------------|
| 5-phase/ CM | NEMA 11 | 32.2 | 285CM005 | 1.2 | 0.05 | 0.72° | 0.56 | 0.009 | 0.1 | DM5-422A | Single -axis |
| | | 32.2 | 285CM005-SZ | 1.2 | 0.05 | 0.72° | 0.56 | 0.009 | 0.1 | DM5-422A | Dual-axis |
| | | 51.8 | 285CM012 | 1.2 | 0.12 | 0.72° | 0.9 | 0.018 | 0.2 | DM5-422A | Single -axis |
| | | 51.8 | 285CM012-SZ | 1.2 | 0.12 | 0.72° | 0.9 | 0.018 | 0.2 | DM5-422A | Dual-axis |
| | NEMA 17 | 39 | 425CM03 | 1.8 | 0.3 | 0.72° | 0.48 | 0.055 | 0.3 | DM5-432A | Single -axis |
| | | 39 | 425CM03-SZ | 1.8 | 0.3 | 0.72° | 0.48 | 0.055 | 0.3 | DM5-432A | Dual-axis |
| | | 47 | 425CM04 | 1.8 | 0.4 | 0.72° | 0.55 | 0.071 | 0.38 | DM5-432A | Single -axis |
| | | 47 | 425CM-SZ | 1.8 | 0.4 | 0.72° | 0.55 | 0.071 | 0.38 | DM5-432A | Dual-axis |
| | | 59 | 425CM05 | 1.8 | 0.5 | 0.72° | 0.64 | 0.11 | 0.49 | DM5-432A | Single -axis |
| | | 59 | 425CM05-SZ | 1.8 | 0.5 | 0.72° | 0.64 | 0.11 | 0.49 | DM5-432A | Dual-axis |
| | NEMA 24 | 55 | 605CM11 | 2.4 | 1.15 | 0.72° | 0.38 | 0.29 | 0.75 | DM5-440A | Single -axis |
| | NEMA 25 | 55 | 605CM11-SZ | 2.4 | 1.15 | 0.72° | 0.38 | 0.29 | 0.75 | DM5-440A | Dual-axis |
| | NEMA 26 | 85 | 605CM21 | 2.4 | 2.1 | 0.72° | 0.64 | 0.54 | 1.2 | DM5-440A | Single axis |
| | NEMA 27 | 85 | 605CM21-SZ | 2.4 | 2.1 | 0.72° | 0.64 | 0.54 | 1.2 | DM5-440A | Dual-axis |

Closed Loop Stepper Drive Part Numbers

CS - **D** **50** **7** -

| Series Name | |
|-------------|-----------------------|
| CS | New Series |
| ES2 | Vector Control Series |
| ES | Classical Series |

| Control Mode | |
|--------------|------------------|
| 3E- | EtherCAT Control |
| 2RS- | Rs485 Modbus RTU |
| 1 or Blank | Pulse Control |

| Product Type | |
|--------------|-------|
| D | Drive |

| AC or DC | |
|----------|--------------------------------------|
| Blank | DC |
| A | AC (except ES-DH1208 and ES-DH2306) |

| Grade | |
|-------|------------------|
| Blank | Standard |
| E | Economic |
| S | High Performance |

| Max Peak Current | |
|------------------|------|
| 3: | 7: |
| 3.0A | 7.0A |
| 6: | 8: |
| 6.0A | 8.0A |

| Max Power Voltage | |
|-------------------|-----------------------|
| 50 | 50V |
| 80 | 80V |
| 100 | 100V±10% |
| 120 | 120V±10% |
| 230 | Single-phase 230V±10% |

Closed Loop Stepper Motor

CS - **M** **2** **34** **85** -

| Series Name | |
|-------------|------------------|
| CS | New Series |
| ES2 | Special Series |
| ES | Classical Series |

| Product Type | |
|--------------|-----------------------------|
| M | Low or Medium Voltage Motor |
| MH | High Voltage Motor |

| 2 or 3 Phase Motor | |
|--------------------|---------------|
| 2 | 2-phase Motor |
| 3 | 3-phase Motor |

| Series Name | |
|-------------|-----------------|
| 0 | NEMA 8 (20mm) |
| 8 | NEMA 11 (28mm) |
| 1 | NEMA 17 (42mm) |
| 1 | NEMA 23 (57mm) |
| 1 | NEMA 24 (60mm) |
| 7 | NEMA 34 (86mm) |
| 2 | NEMA 42 (110mm) |

| Customized | |
|------------|----------------------------------|
| Blank | 1000 ppr Encoder |
| E2Z | 2500 ppr Encoder |
| E5Z | 5000 ppr Encoder |
| S | Inch Diameter (6.25mm or 12.7mm) |
| L | Large NEMA 23 motor |

| Standard Customized Spe. | |
|--------------------------|------------------------|
| Blank | Standard |
| B | Brake |
| WP | Waterproof (Rate IP65) |

| Holding Torque | |
|----------------|------------|
| 013: 0.13N.m | 30: 3.0N.m |
| 02: 0.2N.m | 31: 3.1N.m |
| 06: 0.6N.m | 45: 4.5N.m |
| 08: 0.8N.m | 80: 8.0N.m |
| 13: 1.3N.m | 85: 8.5N.m |
| 23: 2.3N.m | 120: 12N.m |
| 26: 2.6N.m | 200: 20N.m |



2CS3EIP Series \ 2CS3E Series

Fieldbus Closed Loop Stepper Drives

- Support EtherCAT(EtherNet/IP) fieldbus
- Matching most of master controller
- No loss of step, Excellent performance

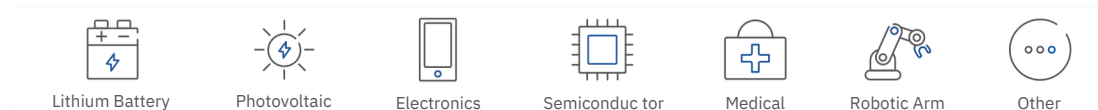

Overview

○ EtherCAT(EtherNet/IP) Communication

- Support EtherNet/IP communication.
- Support great majority of master station such as Beckhoff, Omron, KEYENCE, Panasonic etc.
- Support position, velocity, and homing control mode.

○ More Efficient by Dual-axis Control

- One drive controls two axes via one IP address, highly reduce communication load rate.
- Two axes are independently controlled.

○ STO Optional

- Safe torque off (STO) ensure the safety system.

○ Saving Cost

- One dual-axis drive is more economy than two single-axis drives.

○ Saving Mounting Space

- 10% thickness reducing compared to one single-axis drive.
- 50% at least mounting space saving compared to two single-axis drives.

○ Closed-loop control

- Without losing steps in high speed operation.
- Encoder resolution: 1000 / 2500 / 5000 line for NEMA11/17/23/24/ 34 CS motors.

Specifications

| Models | Operating Voltage | Output Current (A) | Matching Motor | Weight (kg) | Dimension (mm) |
|----------------------|--|--------------------|----------------|-------------|----------------|
| 2CS3EIP -D503 | 20-50VDC | 0.5-2.2 | NEMA8/11/14/17 | 0.4 | 155*116.5*2 |
| 2CS3EIP -D507 | 20-50VDC | 1.0-5.6 | NEMA17/23/24 | 0.4 | 8 |
| 2CS3E-D503 | 20-50VDC | 0.5-2.2 | NEMA8/11/14/17 | 0.4 | 155*116.5*2 |
| 2CS3E-D507 | 20-50VDC | 1.0-5.6 | NEMA17/23/24 | 0.4 | 8 |
| Termination Resistor | The last node needs to add the terminal resistance generally | | | | 155*116.5*2 |
| Tuning cable | CABLE-USB1M5 | | | | 8 |
| CABLE-TX*M*-BUS | Network Cable: 0.1m, 0.2m, 0.3m, 0.4m, 1m, 1.5m, 2m, 3m,5m,7m, 10m,15m,20m | | | | 155*116.5*2 |

2CS3EIP Series \ 2CS3E Series

Unit: mm

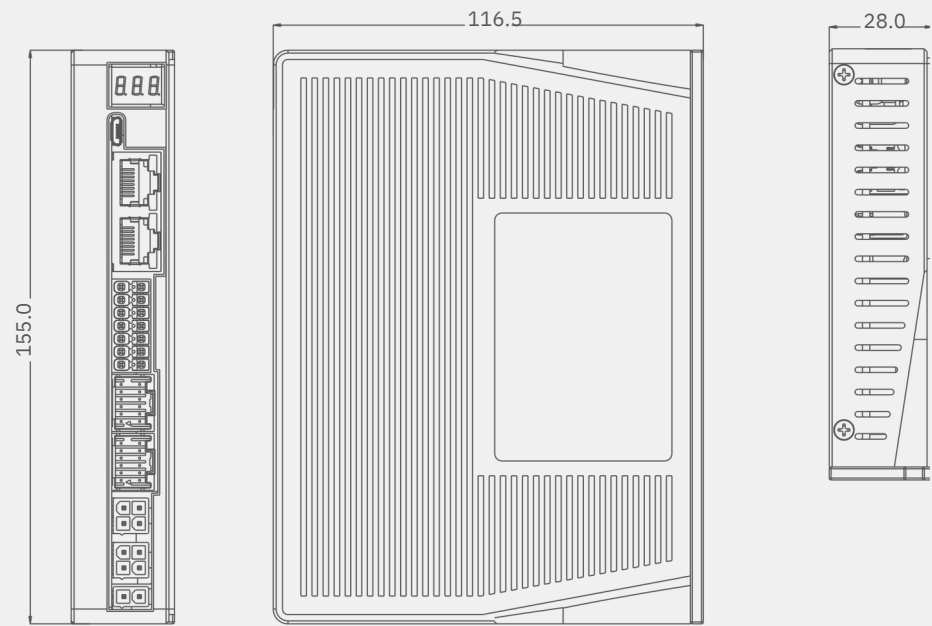

Drive Wiring Diagram

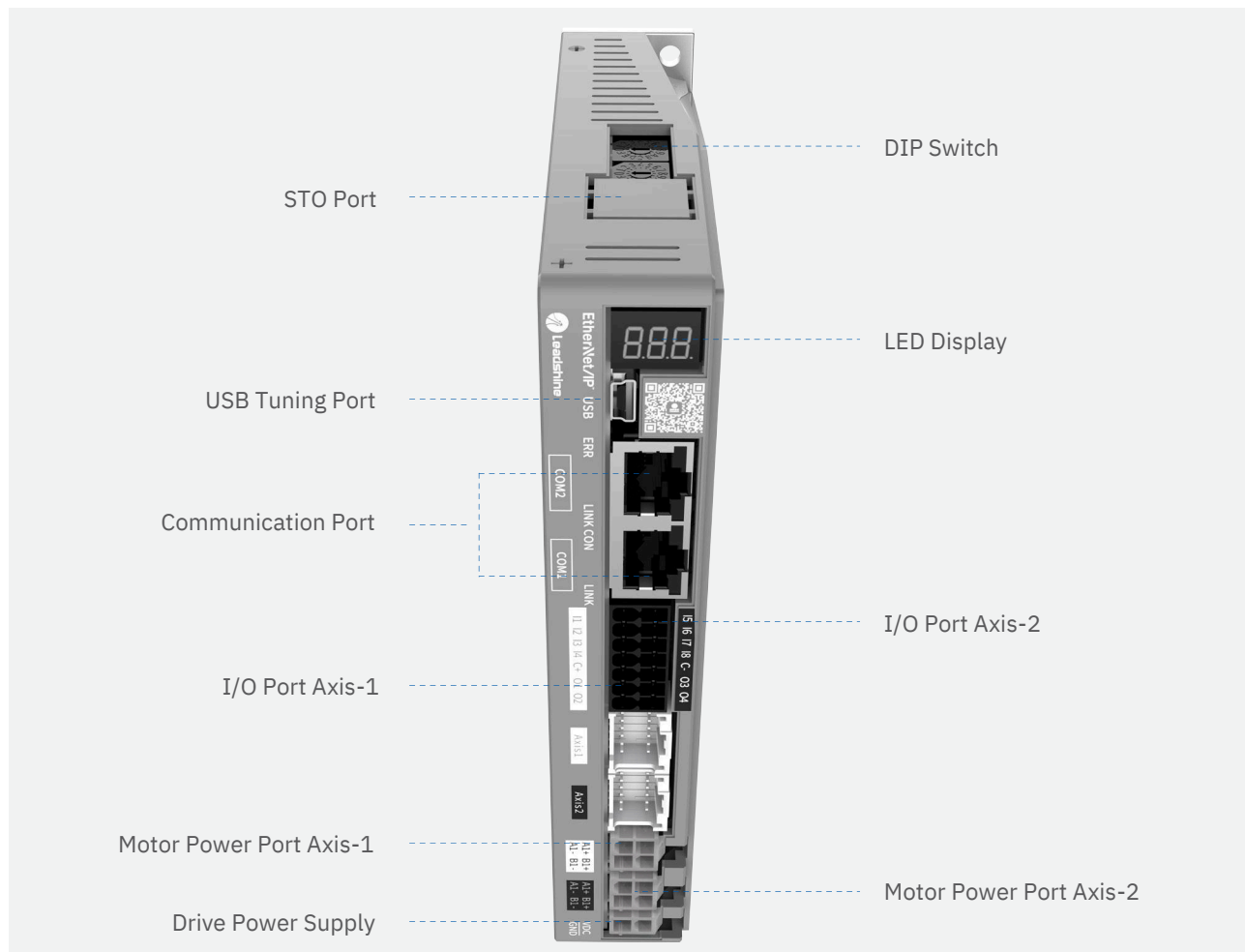
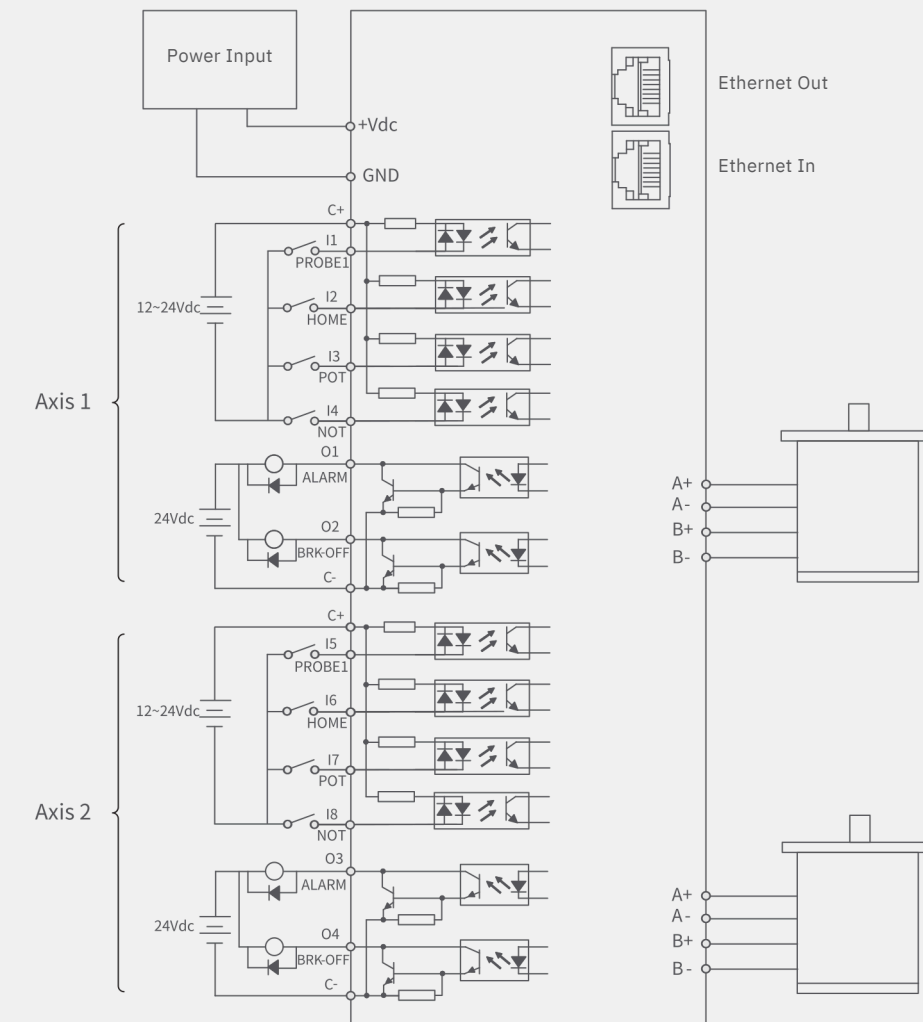



CS3E Series

Fieldbus Closed Loop Stepper Drives

- Support CoE control and CiA 402 protocol
- Matching most of master controller
- Conformance tested by ETG
- No loss of step, Excellent performance

The CS3E series drives support operating modes: Cyclic Synchronous Position (CSP), Profile Position (PP), Profile Velocity (PV), Homing(HM). The products can be matched with most of EtherCAT controller/PLC such as Beckhoff, Omron, Trio, etc.

They have excellent performance including enhanced reliability, super-low noise, anti-resonance, low-speed ripple smoothing and remains 40% less cost than network servo at least. Can power 2-phase NEMA8,11, 14, 17, 23, 24 and 34 stepper motors with incremental encoder in many industrial applications such as CNC, medical, electronics, packaging...

Overview

- No loss of step, No hunting, No torque reservation.
- CS3E support standard EtherCAT protocol with operation modes of PP, PV, CSP, HM.
- 7 configurable digital inputs, 7 optically isolated digital outputs include brake output.
- USB port for parameters configuration.
- Two 7-segment display velocity or slave ID or operation mode or error code.
- Encoder resolution: 1000 / 5000 line for NEMA11/14/17/23/24/ 34 CS motors.
- Thickness reduce to 28mm, more benefit for mounting.
- Friendly type-C tuning port.
- Improve network anti-interference ability.
- Protections for over-voltage, over-current and position following error, encoder wiring error, etc.

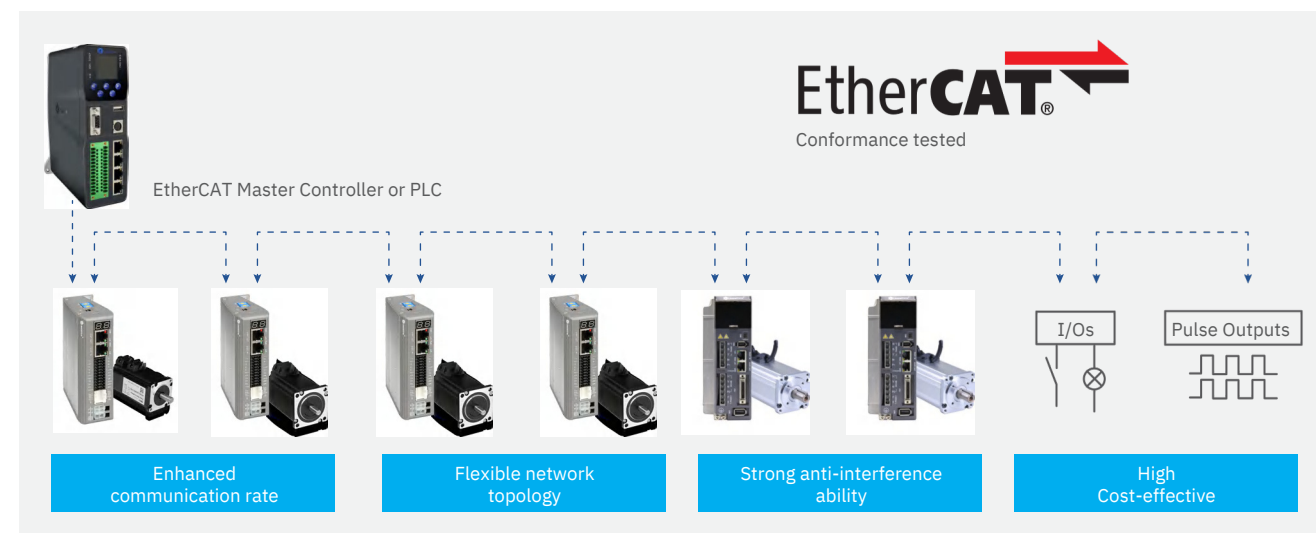

Specifications

| Models | Operating Voltage | Output Current (A) | Matching Motor | Weight (kg) | Dimension (mm) |
|-----------------|---|--------------------|----------------|-------------|----------------|
| CS3E-D503B | 20-50VDC | 0.1-3.0A | NEMA8/11/14/17 | 0.28 | 118*90*2 |
| CS3E-D507B | 20-50VDC | 0.1-7.0A | NEMA17/23/24 | 0.28 | 8 |
| CS3E-D1008 | 20-80VAC or 30-100VDC | 0.5-8.0A | NEMA34 | 0.85 | 118*90*2 |
| Tuning Cable | CABLE-TYPEC2M0 | | | | 8 |
| CABLE-TX*M*-BUS | Network Cable: 0.1m, 0.2m, 0.3m, 0.4m, 1m, 1.5m, 2m, 3m,5m,7m, 10m,15m, 20m | | | | 151*97*5 |
| CABLEM-BM*M* | Encoder Extension Cable | | | | 2 |
| CABLEM-RZ*M* | Motor Extension Cable | | | | |

CS3E Series

Unit: mm

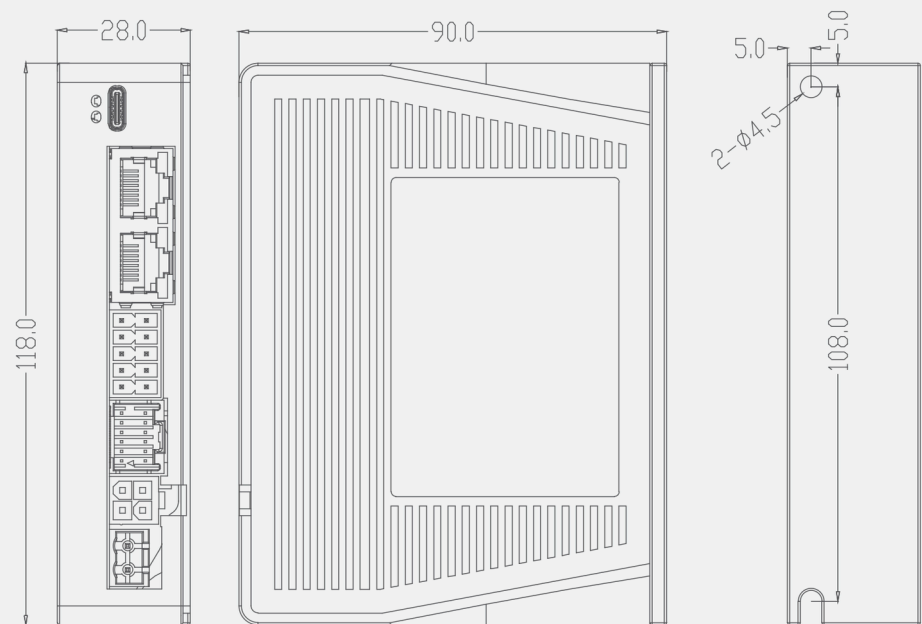

Node Address Dip-switch



USB Tuning Port

EtherCAT OUT

EtherCAT IN

I/O Port

Motor Power Line Port

Power Input Port

Drive Wiring Diagram

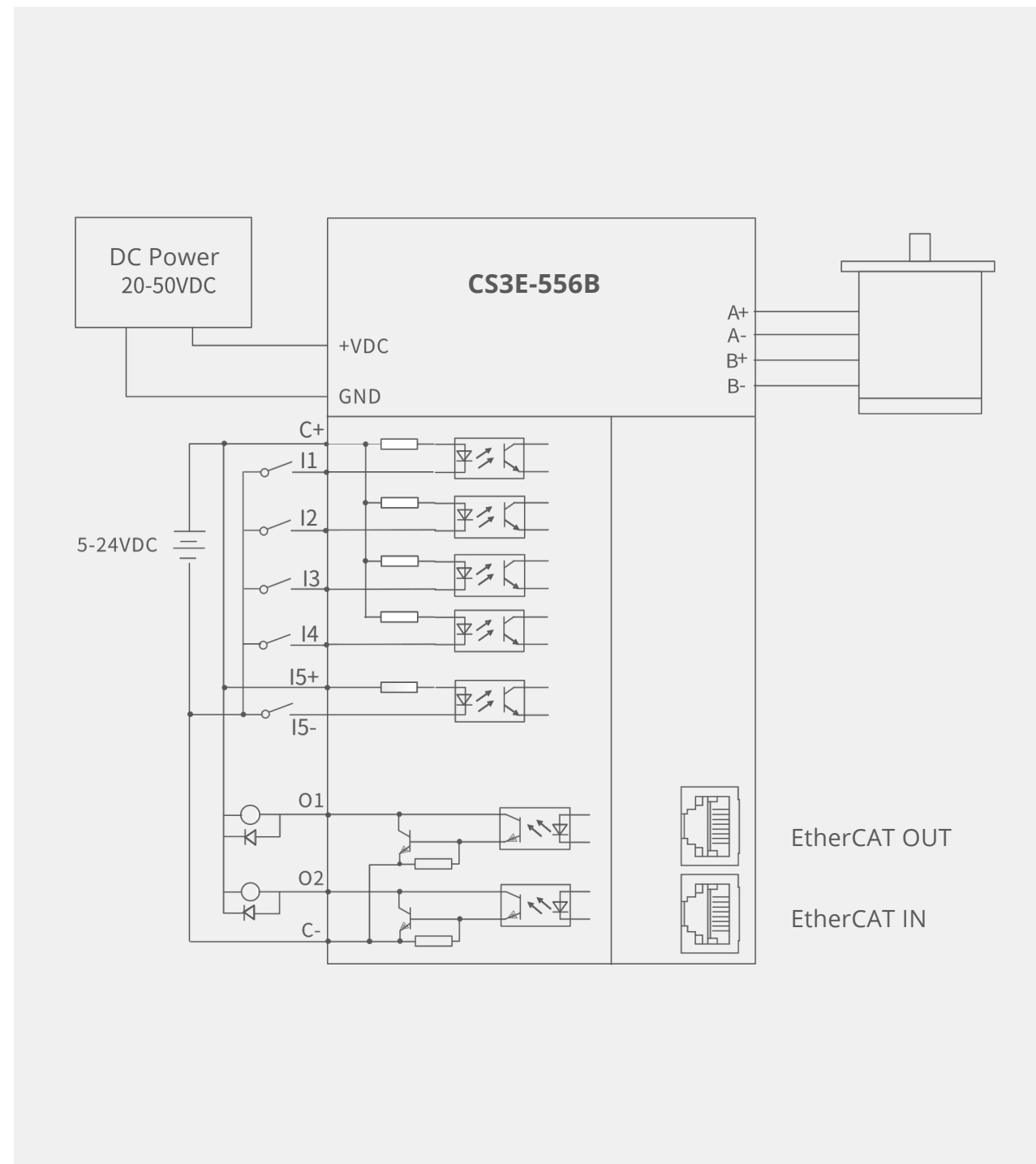



CS2RS Series

Fieldbus Closed Loop Stepper Drives

- Standard Isolated RS485 Modbus
- No loss of step & smooth motion
- Built-in Uni-axial Control Instruction
- HMI, PLC or External I/O start motion

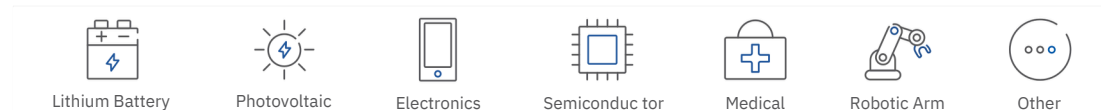

Overview

7 Programmable Inputs

- Limit + / - or Origin inputs
- Quick stop, Alarm reset and Enable inputs
- JOG + / - or Position Table inputs

3 Programmable Outputs

- Alarm, Brake outputs
- Homing / Instruction / Path complete

Modes of Operation

- Velocity
- Position
- Homing

Support Functions

- Teaching Interrupt Skip,
- Suspend, Circulate motion
-

PC Software for Easy Setup, Fine Tune, Matching Motors

- NEMA8, 11,17, 23, 24, 34
- Standard, dual shaft, brake, waterproof

Support RS485 communication

- Adopted closed loop step system to make real-time position error correction ,can eliminate potential loss of step.

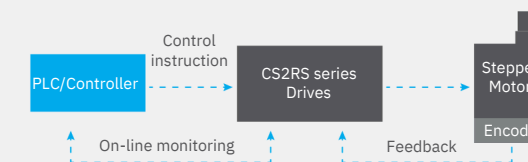

Built-in uni-axial control instruction

- Programmable 16-segment position table, support positioning / homing / limit / quick stop / JOG...

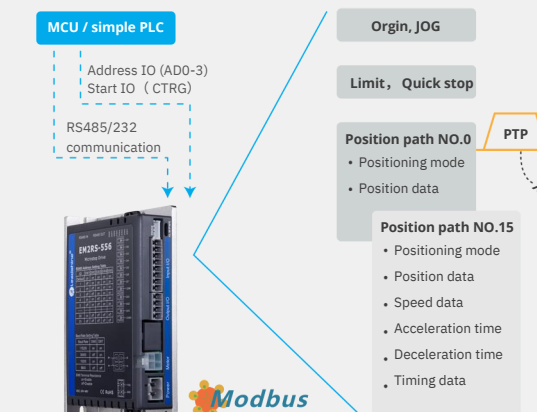

Support RS485 communication

- Standard Modbus RTU protocol, RS485 communication can network up to 31 axes

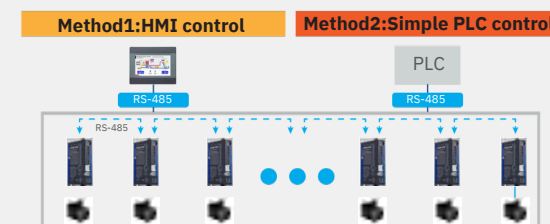

Specifications

| Models | Operating Voltage | Output Current (A) | Matching Motor | Weight (kg) | Dimension (mm) |
|-----------------|-----------------------|--------------------|-------------------------|-------------|----------------|
| CS2RS-D503 | 20-50VDC | 0.5- | NEMA8/11/14/17 | 0.3 | 116*69.2*26.5 |
| CS2RS-D507 | 20-50VDC | 3.0 | NEMA17/23/24 | 8 | 116*69.2*26.5 |
| CS2RS-D1008 | 20-80VAC or 30-100VDC | 0.5- | NEMA24/34 | 0.3 | 151*97*53 |
| Tuning Cable | | 7.0 | CABLE-PC-1 | 8 | |
| CABLEM-BM*M* | | 0.5- | Encoder Extension Cable | 0.5 | |
| CABLE-TX*M*-BUS | | 8.0 | Motor Extension Cable | 7 | |



CS1 Enhanced Version CS Cost-effective Version

Pulse Control Closed Loop Stepper Drives

CS1 Series----Enhanced Performance

Overview

- New generation of algorithm
- Noise reduction improved by 20db
- Vibration reduction improved by 30%
- Temperature rise reduction improved by 20°C

Inputs and Outputs

- Step & DIR (CW & CCW) inputs
- Alarm output and In Position output
- Encoder A/B/Z outputs
- Enable input and Error Reset input
- Brake outputs

Switch Settings

- Microstep resolution
- Pulse Mode
- Closed / Open Loop Mode
- Gain adjustment and output current
- Rotation direction
- Positional command filter
- Encoder resolution
- 5V or 24V signal voltage optional

Specifications

| Items | CS1-D503S | | CS1-D507S | | CS1-D728S | |
|-----------------------|-----------|-----|-----------|-----|-----------|-----|
| | Min | Max | Min | Max | Min | Max |
| Output Current (A) | 0.5 | 3 | 0.5 | 7 | 0.5 | 8 |
| Power Voltage (VDC) | 20 | 50 | 20 | 20 | 20 | 72 |
| Input Frequency (kHz) | - | 500 | - | 500 | - | 500 |

Closed Loop Stepper Motors and Drives

Pin Assignments

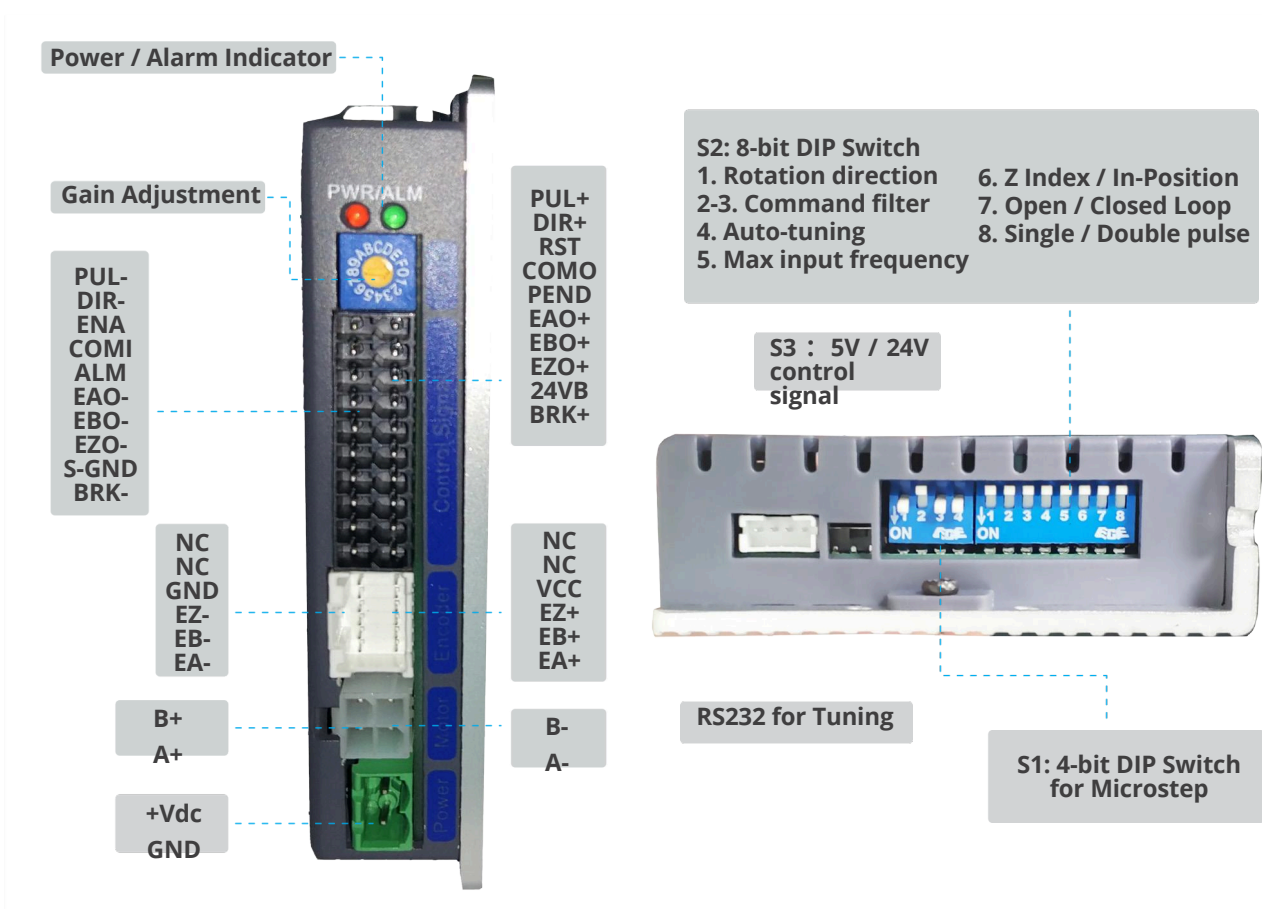

CS Series---Cost-effective Version

The CS series consists of ES seasy servo drives adopting Leadshine latest advanced closed loop control technology. Those drives are highly reliable with good performance and highly competitive cost. They can power a wide range of closed loop stepper motors from NEMA 8 to NEMA 34 (model dependent) with incremental encoders. CS series drives are easy to configure and setup.



| Model | CS-D508 | CS-D808 | CS-D507E | CS-D1008E |
|------------------------|--------------------------|-----------|-----------|-----------------------|
| Operating Voltage | 20-50 VDC | 20-80 VDC | 20-50 VDC | 20-80VAC or 30-110VDC |
| Peak Output Current | 0.5-7.0A | 0.5-8.0A | 0.5-7.0A | 0.5-8.0A |
| Control Signal Voltage | 5V | | 5/24V | |
| Max. Input Frequency | 200KHz (500kHz optional) | | | |

CS Series

Unit: mm

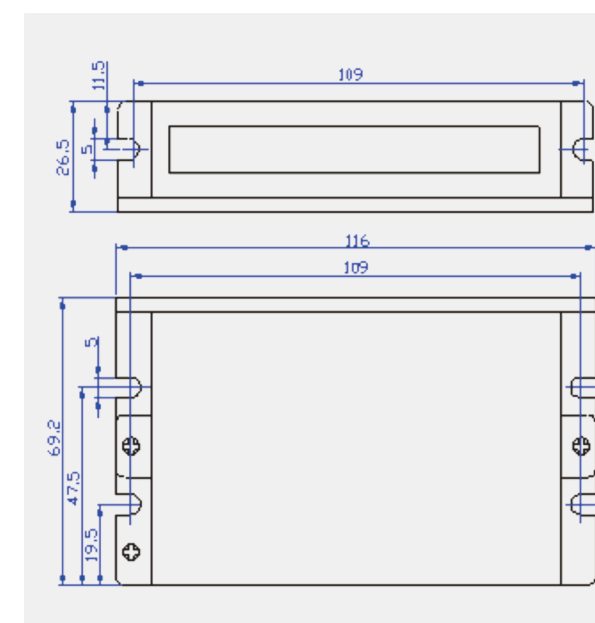
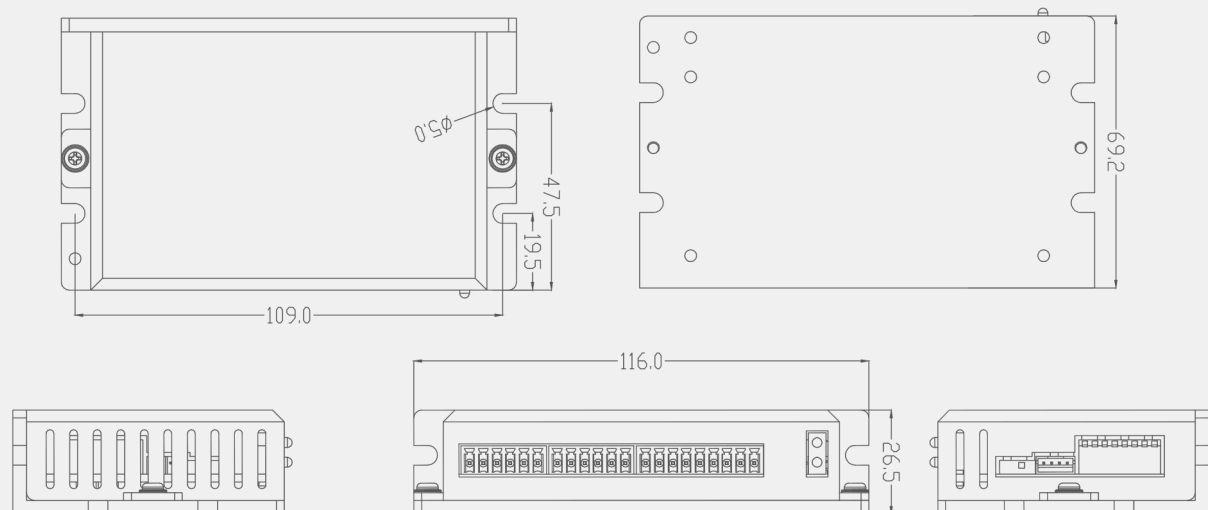

CS-D508 / CS-D507E

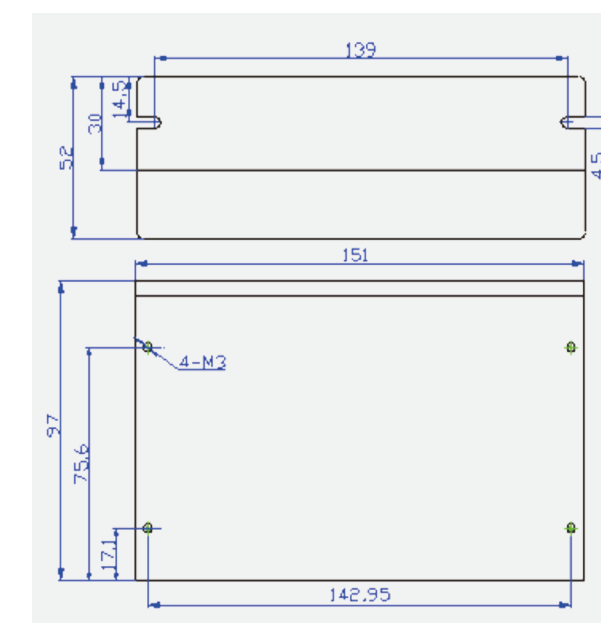

CS-D808 / CS-D1008E



Closed Loop Stepper Motors

CS-M Series

- Replace ES-M series easy servo motor
- Frame size of NEMA 8 to 34
- High reliability and high precision
- Reliable encoder solution

Introduction

CS-M series closed loop stepper motor integrated the cm series stepper motor and encoder, which can provide large torque, low heat and reliable position feedback signals. CS-M series also includes the types with brake, waterproof and different resolution. As a result of large-scale automated production lines and strict quality management system, CS-M series motors are more stable, reliable, superior, consistent and has a lower lost.

Most of ES-M easy servo motors will be replaced by CS-M motors.

Encoder Specifications

| | |
|--------------------|------------------------------|
| Encoder Resolution | 1000 ppr, 2500 ppr, 5000 ppr |
| Encoder Current | Typical 56mA / Max. 59mA |
| Low Level | 0.4v@20mA Max |
| High Level | 2.4v@-20mA Min |

Motor Specifications

| | |
|-----------------------|--|
| Step Angle | 1.8° |
| Position Accuracy | ±0.09° |
| Temp Rise (Max.) | Max. 85K |
| Operation Environment | Temperature: -10°C ~ +50°C; Humidity: Max. 85% |
| Insulation Class | B |
| Insulation Resistance | Min.100 MΩ, 500 V DC |
| Dielectric Strength | 500 VAC, 1 min |
| Radial Play | 0.025 mm Max. (Load 5N) |
| Axial Play | 0.075 mm Max. (Load 10N) |

Installation & Operation Conditions

| Motor Size | NEMA17 | NEMA23 | NEMA24 | NEMA34 |
|---|--|--------|--------|--------|
| Store Temperature | -10°C ~ +50°C | | | |
| Store Humidity | Max. 85% | | | |
| Operation Environment | Non-corrosive gas and dust; No direct contact with water, oil (except the waterproof type) | | | |
| Radial Load(N) (Distance to the flange 10mm) | 30 | 75 | 90 | 300 |
| Axial Load(N) | Less than motor weight | | | |

NEMA 17 (42mm)



| Models | Length (mm) | Holding Torque (N.m) | Rate Current (A) | Inertia (kgm ² *10 ⁻⁴) |
|-----------|-------------|----------------------|------------------|---|
| CS-M21702 | 56 | 0.2 | 1.5 | 0.023 |
| CS-M21704 | 63 | 0.4 | 1.5 | 0.045 |
| CS-M21706 | 70 | 0.6 | 2.5 | 0.077 |
| CS-M21708 | 83 | 0.8 | 2.5 | 0.11 |

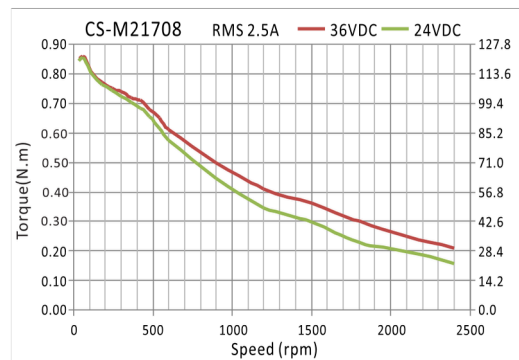
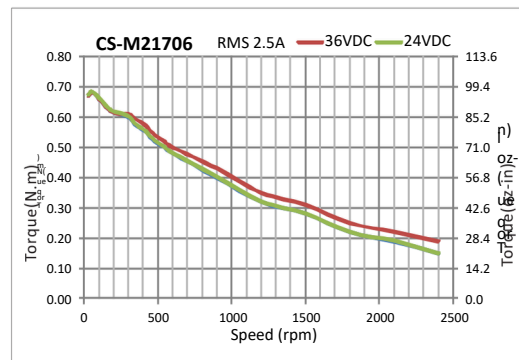
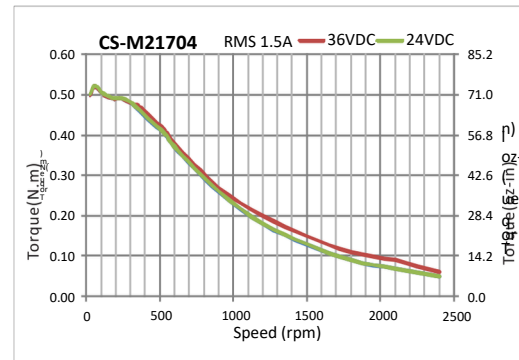
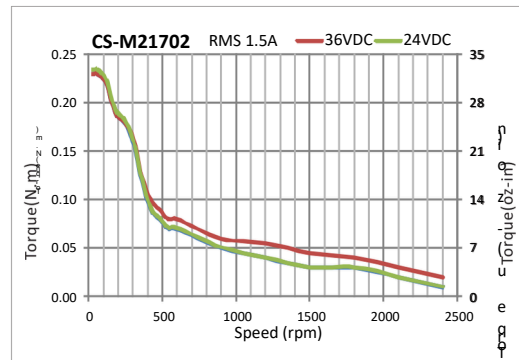
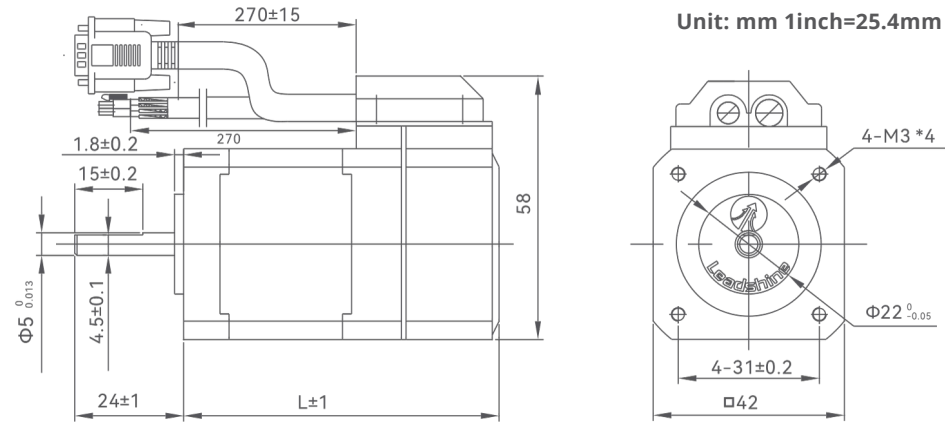

NEMA 23 (57mm)



| Models | Length (mm) | Holding Torque (N.m) | Rate Current (A) | Inertia (kgm ² *10 ⁻⁴) |
|-----------|-------------|----------------------|------------------|---|
| CS-M22306 | 60 | 0.6 | 3.0 | 0.131 |
| CS-M22313 | 75 | 1.3 | 4.0 | 0.3 |
| CS-M22323 | 95 | 2.3 | 5.0 | 0.48 |
| CS-M22326 | 103 | 2.6 | 5.0 | 0.7 |

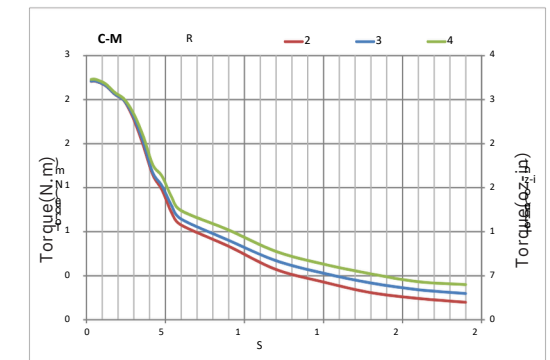
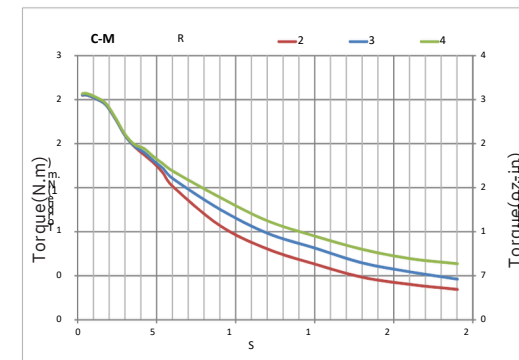
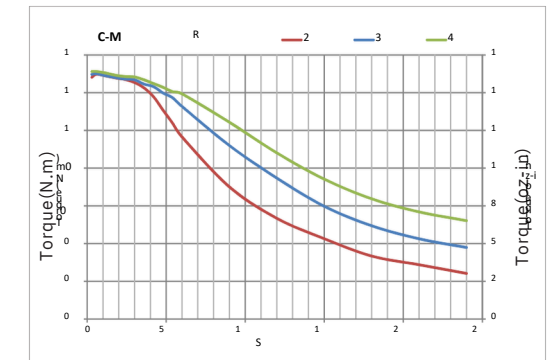
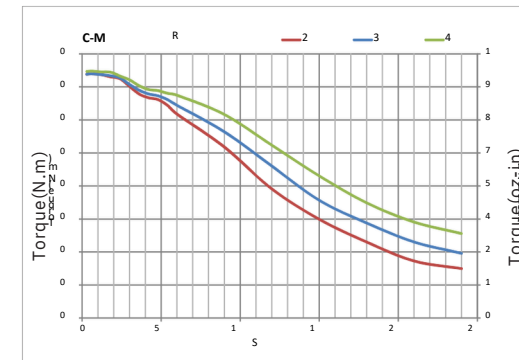
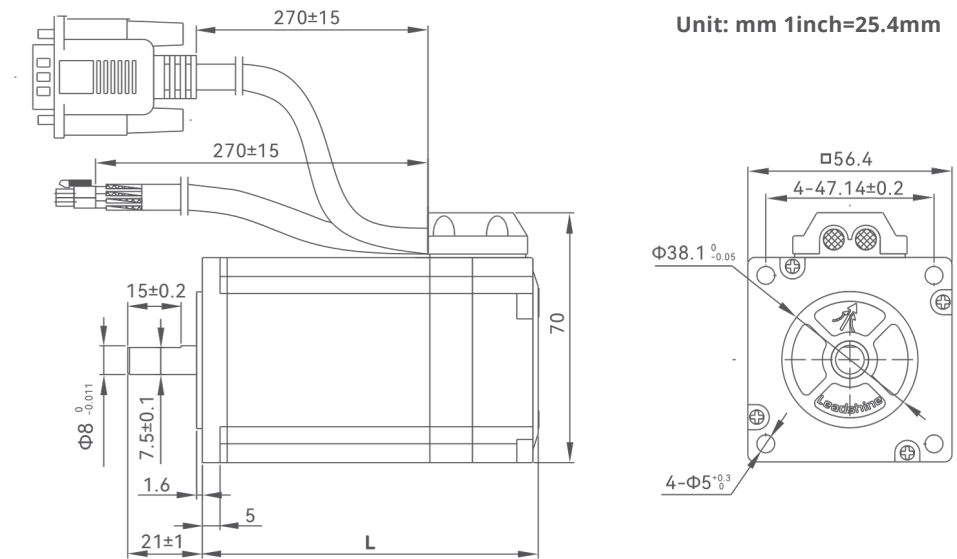

NEMA 23 (57mm)



| Models | Length (mm) | Holding Torque (N.m) | Rate Current (A) | Inertia (kgm ² *10 ⁻⁴) |
|-------------|-------------|----------------------|------------------|---|
| CS-M22321-L | 86 | 2.1 | 5.0 | 0.4 |
| CS-M22331-L | 105 | 3.1 | 5.0 | 9 |

0.6
9

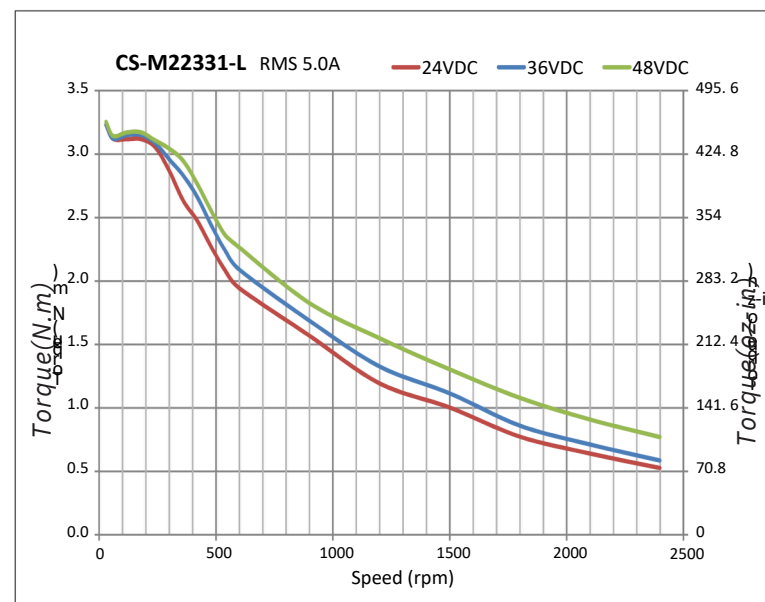
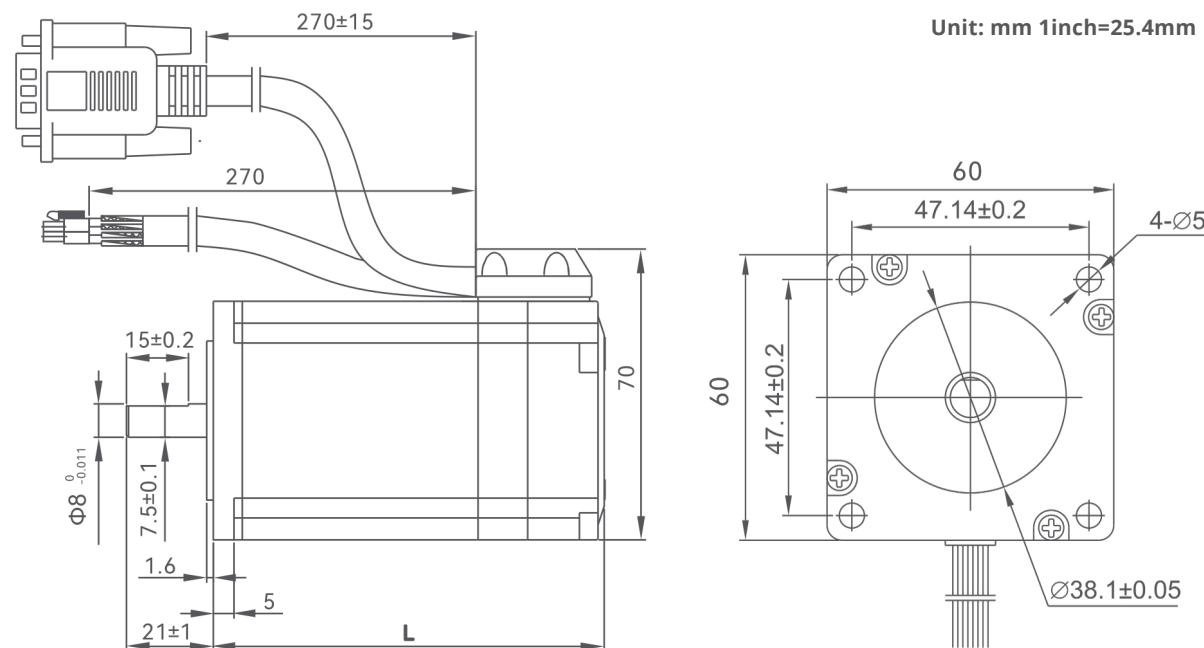

NEMA 24 (60mm)



| Models | Length (mm) | Holding Torque (N.m) | Rate Current (A) | Inertia (kgm ² *10 ⁻⁴) |
|-----------|-------------|----------------------|------------------|---|
| CS-M22422 | 86 | 2.2 | 5.0 | 0.4 |
| CS-M22430 | 103 | 3.0 | 5.0 | 9 |

0.6
9

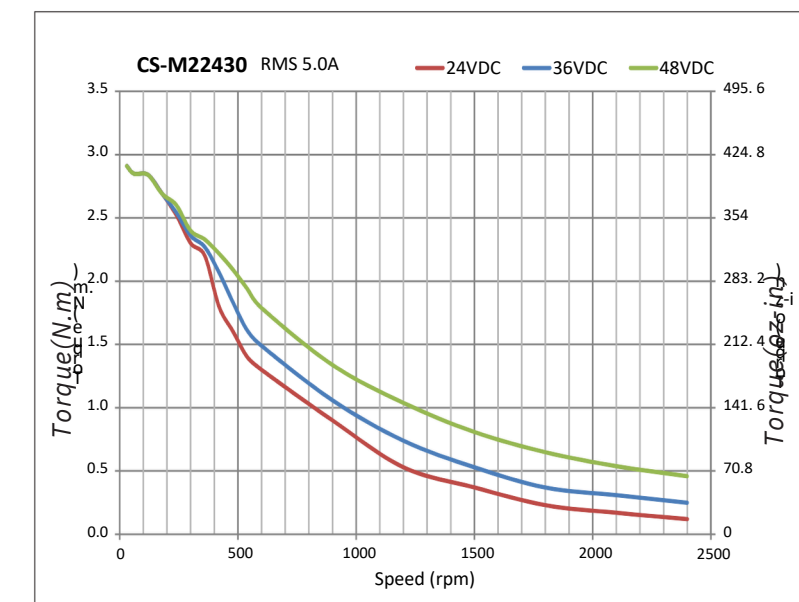
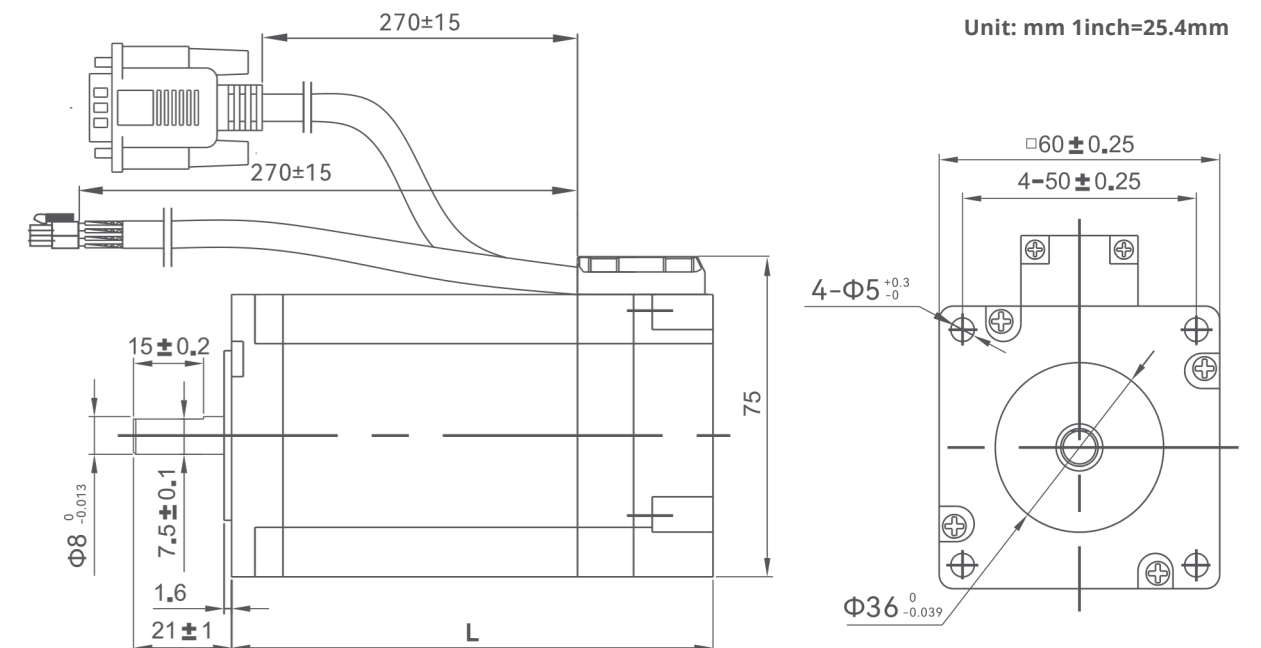

NEMA 34 (86mm)



| Models | Length (mm) | Holding Torque (N.m) | Rate Current (A) | Inertia (kgm ² *10 ⁻⁴) |
|------------|-------------|----------------------|------------------|---|
| CS-M23435 | 95 | 3.5 | 4.0 | 1.0 |
| CS-M23445 | 109 | 4.5 | 6.0 | 1.95 |
| CS-M23480 | 127 | 8.0 | 6.0 | 2.5 |
| CS-M23485 | 147 | 8.5 | 6.0 | 2.8 |
| CS-M234120 | 158 | 12.0 | 6.0 | 3.0 |

Note: Motors with 1/2 in(12.7mm) shaft diameter are available.

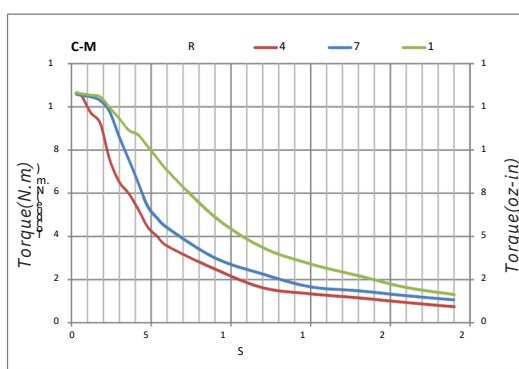
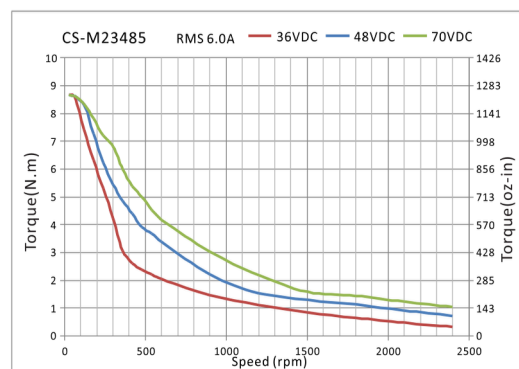
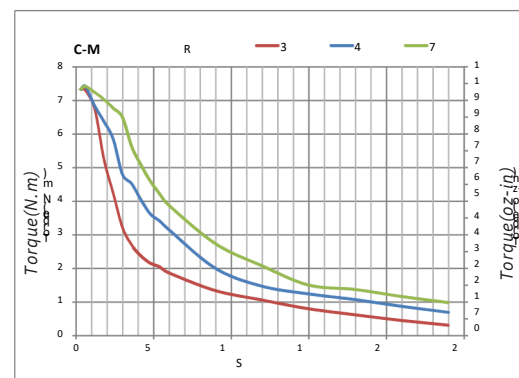
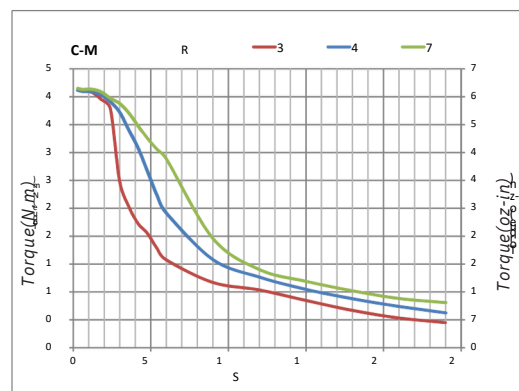
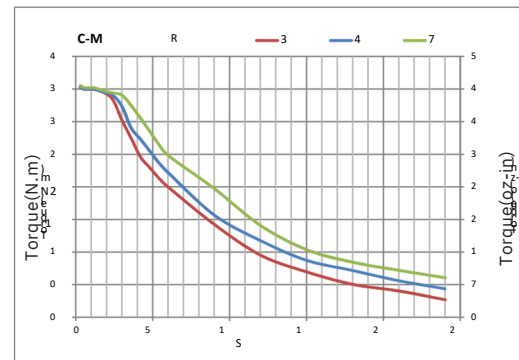
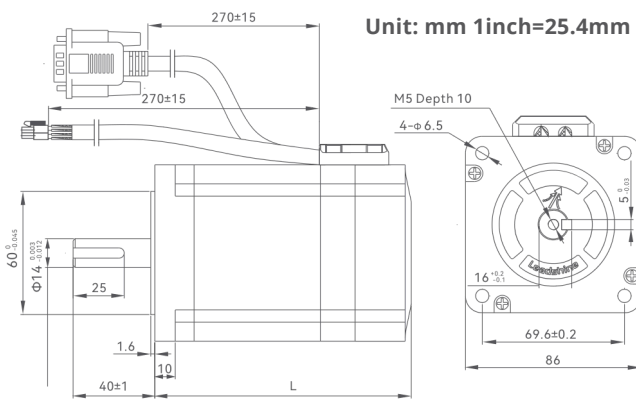

3-phase: NEMA 34, 42



| Models | Length (mm) | Holding Torque (N.m) | Rate Current (A) | Inertia (kgm ² *10 ⁻⁴) |
|--------------|-------------|----------------------|------------------|---|
| ES2-MH33480 | 158 | 8.0 | 6.0 | 3.0 |
| ES2-MH334100 | 185 | 10.0 | 6.0 | 3.0 |
| ES2-MH342120 | 162 | 12.0 | 4.2 | 10.8 |
| ES2-MH342200 | 244 | 20.0 | 5.2 | 17 |

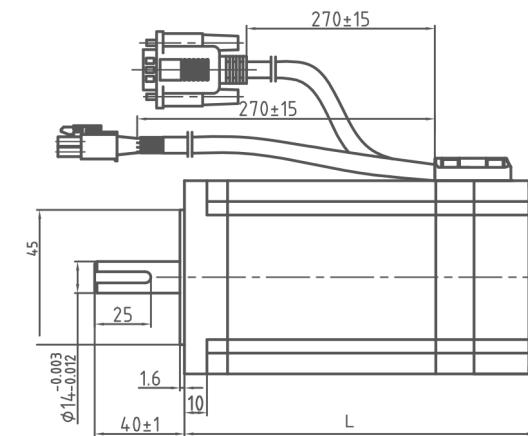

Unit: mm 1inch=25.4mm

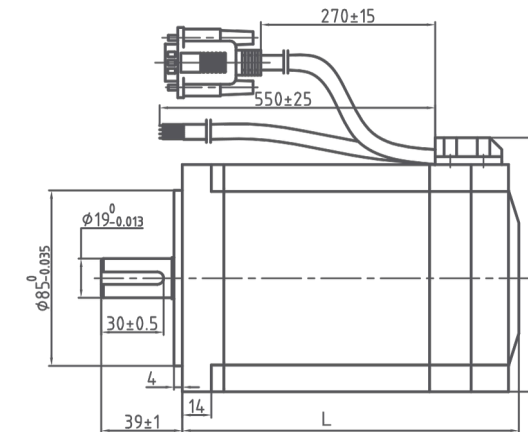
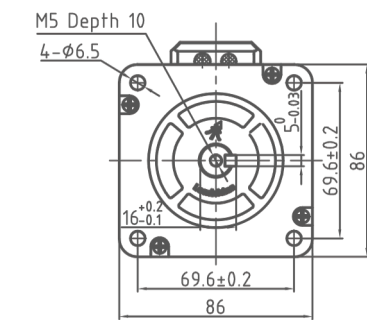

Unit: mm 1inch=25.4mm

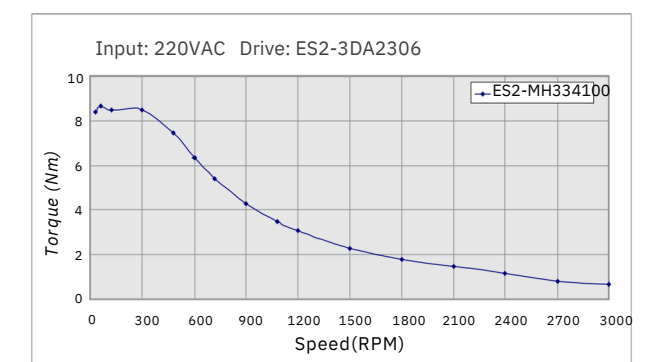
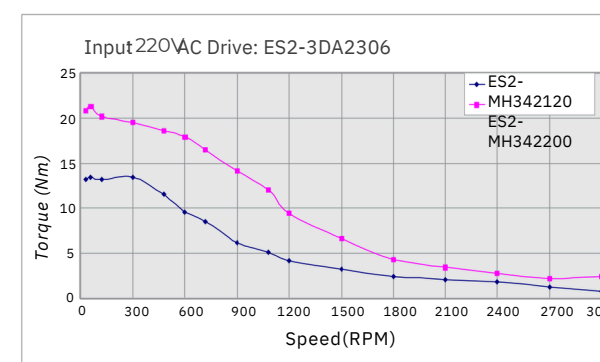
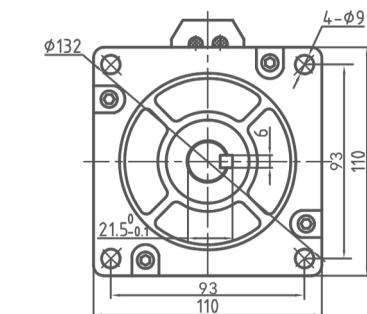



iEM & iCS Series

Integrated Stepper Motor

iEM series is integrated open-loop stepper motor with Leadshine's latest digital stepper technology.

iCS series is integrated closed-loop stepper motor with 14-bit single-turn absolute encoder for smooth and jitter-free motor start-up.

iEM and iCS series motors output torque can up to 3.5Nm and supports Modbus RS485 communication with Indexer control function. And with a more compact design, it is especially suitable for applications with strict mounting space requirements, and it is easy to use, which can further reduce customers' procurement and labor costs.

Extra-low Motor Noise

+

Lower Labor Cost

+

Lower Cable Cost

+

Save Mounting Space

Specifications

| | | | |
|--|--|--------|--------|
| Encoder Type | Single-turn absolute magnetic encoder | | |
| Encoder Resolution | 14-bit | | |
| Angle Calibration | Be sure to calibrate after encoder installation | | |
| Step Angle | 1.8° | | |
| Position Accuracy | ±0.09° | | |
| Max Temperature | 95° C | | |
| Operation Environment | Temperature: -10° C ~ 50° C; Humidity: 85%RH Max | | |
| IP Rate | IP20 | | |
| Radial Load (N) (Distance to the flange 10mm) | NEMA17 | NEMA23 | NEMA24 |
| | 30 | 75 | 90 |
| Axial Load (N) | Less than motor weight | | |

iEM & iCS Interface



DIP Switches
Tuning Port

Signal I/O Interface
Power Input Interface
Indicator

| Port | Description |
|--------------|--|
| DIP Switches | SW1-SW4: Microstep SW5: Motor Direction SW6: PUL&DIR and CW&CCW selection SW7: Smoothing filtering time SW8: Activated pulse edge for iEM series Open/closed loop control selection for iCS series |
| I/O Port | PUL+/-, DIR+/-, ENA+/-, ALM+/- |

Dimensions

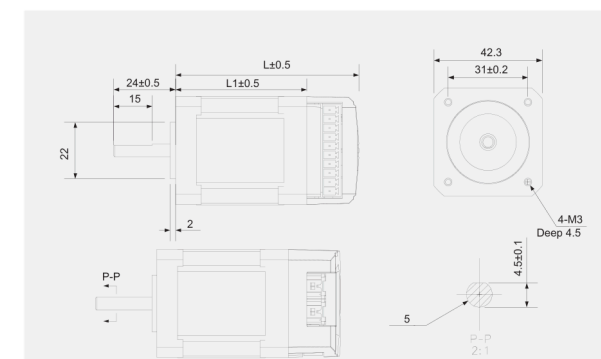

| Model | L1 length | L length |
|----------|-----------|----------|
| iCS-1703 | 43 | 64 |
| iCS-1706 | 51 | 72 |
| iCS-1708 | 64 | 85 |

Unit: mm 1inch=25.4mm

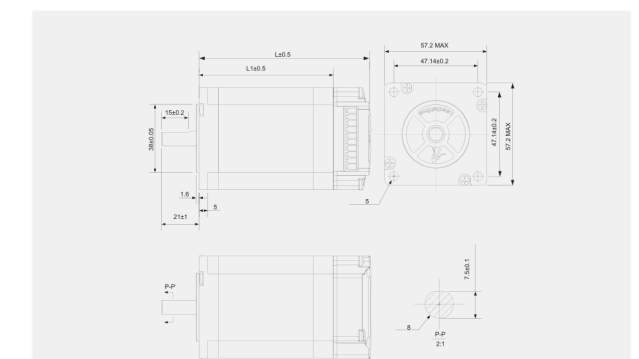

| Model | L1 length | L length |
|------------|-----------|----------|
| iCS-2113 | 43 | 64 |
| iCS-2323 | 51 | 72 |
| iCS-2321-L | 64 | 85 |
| iCS-2331-L | 88 | 109 |
| iCS-2430 | 88 | 109 |
| iCS-2435 | 101 | 122 |

iEM-RS & iCS-RS Interface

| Port | Description |
|--------------|---|
| DIP Switches | SW1-SW5: Node ID SW6-SW7: Baud Rate SW8: 120Ω Terminal Resistance |
| I/O Port | 7 digital inputs, 3 digital outputs |

Dimensions

Unit: mm 1inch=25.4mm

| Model | L1 length |
|------------|-----------|
| iCS-RS1706 | 73mm |
| iCS-RS1708 | 86mm |

| Model | L1 length |
|------------|-----------|
| iCS-RS2313 | 78mm |
| iCS-RS2323 | 99mm |

Built-in uni-axial control instruction

MCU / simple PLC

- Address IO (AD0-3)
- Start IO (CTRG)
- RS485 / 232 communication

Control Instructions:

- Origin, JOG
- Limit, Quick stop
- Position path NO.0 (PTP)
- Position path NO.15 (X16)

Additional data for Positioning mode:

- Positioning mode
- Position data
- Acceleration time
- Deceleration time
- Speed data
- Timing data

Specifications

| Models | Type & Frame | Operating Voltage (VDC) | Control Mode | Holding Torque (N.m) | Logical Voltage (VDC) | Motor Length (mm) |
|------------|--------------------|-------------------------|------------------|----------------------|-----------------------|-------------------|
| iEM-1703 | Open Loop NEMA17 | 20-36 | Pulse&Dir | 0.3 | 5 | 64 |
| iEM-1706 | | 20-36 | | 0.6 | 5 | 72 |
| iEM-1708 | | 20-36 | | 0.8 | 5 | 85 |
| iEM-RS1706 | | 20-36 | RS485 Modbus | 0.6 | 12-24 | 73 |
| iEM-RS1708 | | 20-36 | | 0.8 | 12-24 | 86 |
| iEM-2313 | Open Loop NEMA23 | 20-50 | Pulse&Dir CW&CCW | 1.3 | 5 | 75 |
| iEM-2323 | | 20-50 | | 2.3 | 5 | 96 |
| iEM-2321-L | | 20-50 | | 2.1 | 5 | 89 |
| iEM-2331-L | | 20-50 | | 3.1 | 5 | 109 |
| iEM-RS2313 | | 20-50 | RS485 Modbus | 1.3 | 12-24 | 78 |
| iEM-RS2323 | | 20-50 | | 2.3 | 12-24 | 99 |
| iEM-2430 | Open Loop NEMA24 | 20-50 | Pulse&Dir CW&CCW | 3.0 | 5 | 109 |
| iEM-2435 | | 20-50 | | 3.5 | 5 | 122 |
| iCS-1703 | Closed Loop NEMA17 | 20-36 | Pulse&Dir | 0.3 | 5 | 64 |
| iCS-1706 | | 20-36 | | 0.6 | 5 | 72 |
| iCS-1708 | | 20-36 | | 0.8 | 5 | 85 |
| iCS-RS1706 | | 20-36 | RS485 Modbus | 0.6 | 12-24 | 73 |
| iCS-RS1708 | | 20-36 | | 0.8 | 12-24 | 86 |
| iCS-2313 | Closed Loop NEMA23 | 20-50 | Pulse&Dir CW&CCW | 1.3 | 5 | 75 |
| iCS-2323 | | 20-50 | | 2.3 | 5 | 96 |
| iCS-2321-L | | 20-50 | | 2.1 | 5 | 89 |
| iCS-2331-L | | 20-50 | | 3.1 | 5 | 109 |
| iCS-RS2313 | | 20-50 | RS485 Modbus | 1.3 | 12-24 | 78 |
| iCS-RS2323 | | 20-50 | | 2.3 | 12-24 | 99 |
| iCS-2430 | Closed Loop NEMA24 | 20-50 | Pulse&Dir CW&CCW | 3.0 | 5 | 109 |
| iCS-2435 | | 20-50 | | 3.5 | 5 | 122 |



Headquarters
China Leadshine Technology Co., Ltd.

☎ +86 755 26411692 📠 +86 755 26402718
🌐 www.leadshine.com
✉ sales@leadshine.com (Sales)
 tech@leadshine.com (Technical Support)
📍 15-20/F, Block B, Nanshan i-Valley, Shuguang Community,
 Xili Town, Nanshan District, Shenzhen 518055, China

North America Office
Leadshine America, Inc.

☎ 1-949-608-7270 📠 1-949-638-7298
🌐 www.leadshineusa.com
✉ sales@leadshineusa.com (Sales)
 support@leadshineusa.com (Technical Support)
📍 26050 Towne Centre Dr.Foothill Ranch, CA 92610 USA

Distributors for Italy
ErreUno S.r.l.

☎ 00390521694164
🌐 www.erre1.it
🌐 E-commerce: www.syby.it
✉ info@erre1.it (Sales)
📍 13 Novella Street, 43058 Sorbolo, PR, Italy

